

ADDENDUM TO M300E/EM MANUAL P/N 04288

***MODEL 300EU
CO ANALYZER WITH AUTO-REFERENCE***





**© TELEDYNE INSTRUMENTS
ADVANCED POLLUTION INSTRUMENTATION DIVISION
(TAPI)
9480 CARROLL PARK DRIVE
SAN DIEGO, CALIFORNIA 92121-5201
USA**

**Toll-free Phone: 800-324-5190
Phone: 858-657-9800
Fax: 858-657-9816
Email: api-sales@teledyne.com
Website: <http://www.teledyne-api.com/>**

SAFETY MESSAGES

Your safety and the safety of others are very important. We have provided many important safety messages in this manual. Please read these messages carefully.

A safety message alerts you to potential hazards that could hurt you or others. Each safety message is associated with a safety alert symbol. These symbols are found in the manual and inside the M300EU Analyzer. The definition of these symbols is described below:

	<p>GENERAL SAFETY HAZARD: Refer to the instructions for details on the specific hazard.</p>
	<p>CAUTION: Hot Surface Warning.</p>
	<p>CAUTION: Electrical Shock Hazard.</p>
	<p>TECHNICIAN SYMBOL: All operations marked with this symbol are to be performed by qualified maintenance personnel only.</p>

CAUTION

The Model 300EU, CO Analyzer with Auto-Reference, should only be used for the purpose and in the manner described in this manual. If you use the M300EU in a manner other than that for which it was intended, unpredictable behavior could ensue with possible hazardous consequences.

NOTE

Technical Assistance regarding the use and maintenance of the M300EU or any other Teledyne Instruments product can be obtained by:

Contacting Teledyne Instruments' Customer Service Department at 800-324-5190

or

Via the internet at <http://www.teledyne-api.com/>

USER NOTES:

USER NOTES:

TABLE OF CONTENTS

1. INTRODUCTION	III
1.1. Reference Numbering convention	1
1.2. M300EU Overview	1
2. SPECIFICATIONS, APPROVALS AND WARRANTY	3
2.1. Specifications	3
2.2. EPA Equivalency Designation	4
2.3. CE Mark Compliance	4
2.4. Warranty.....	4
3. GETTING STARTED	4
3.1. Unpacking the M300EU.....	5
3.2. M300EU analyzer Layout	5
3.3. Electrical Connections	6
3.3.1. Power Connection	6
3.3.2. Analog Output Connections.....	7
3.3.3. Connecting the Status Outputs.....	8
3.4. Initial Operation of the M300EU	9
3.4.1. Startup and Warm up of the M300EU.....	9
3.4.2. Warning Messages.....	9
3.4.3. Functional Check.....	10
3.5. Initial Calibration.....	11
3.5.1. Pre-Calibration Stabilization	11
3.5.2. Basic CO Calibration SETUP	11
3.5.2.1. Calibration Gases	11
3.5.3. Basic CO Calibration Procedure.....	12
4. FREQUENTLY ASKED QUESTIONS & GLOSSARY	13
5. OPTIONAL HARDWARE AND SOFTWARE	15
5.1. Calibration Valve Options for the M300EU	16
5.1.1. Zero Span Valves (OPT 50A).....	16
5.1.2. Zero Span Valves with IZS (OPT 51B).....	17
5.1.3. Zero Span Valves with IZS and Shutoff VALVE (OPT 51B).....	18
6. M300EU OPERATING INSTRUCTIONS	19
6.1. Summary of differences between operating the M300EU and the M300E/EM analyzers.	19
6.2. Operating Modes.....	20
6.2.1. Auto-Reference Mode (AREF).....	21
6.2.2. Test Functions.....	22
6.3. SETUP → RNGE: Analog Output Reporting Range Configuration	23
6.3.1. Physical Range versus Analog Output Reporting Ranges.....	23
6.3.2. Analog Output Ranges for CO Concentration.....	23
6.3.3. RNGE → MODE → SNGL: Configuring the M300EU analyzer for Single Range Mode.....	25
6.3.4. RNGE → MODE → DUAL: Configuring the M300EU analyzer for Dual Range Mode	26
6.3.5. RNGE → MODE → AUTO: Configuring the M300EU analyzer for Auto Range Mode	27
6.3.6. SETUP → RNGE → UNIT: Setting the Reporting range Unit Type	28
6.4. SETUP → MORE → AREF: Configuring and Performing Auto-Reference Measurements.....	29
6.4.1. Adjusting the A-REF Mode Cycle Time	29
6.4.2. Forcing an Auto-Reference measurement.....	30
6.5. SETUP → MORE → VARS: Internal Variables (VARs).....	32
6.6. SETUP → MORE → DIAG: Using the Diagnostics Functions.....	33
6.7. Analog Output Configuration	34
6.7.1. Analog I/O Configuration	34
6.7.2. Calibration of the Analog Outputs.....	37
6.7.3. Selecting a Test Channel Function for Output A4.....	38
6.7.4. Hessen Protocol	39
7. CALIBRATION PROCEDURES	41
8. EPA PROTOCOL CALIBRATION	43
9. INSTRUMENT MAINTENANCE	45
9.1. Performing an Auto-Reference Measurement after maintenance.....	45
10. THEORY OF OPERATION	49
10.1. Measurement Method.....	49
10.1.1. Auto-reference Ratio.....	49
10.2. Pneumatic Operation.....	50
10.2.1. The A-REF Valve assembly.....	50
10.2.2. The Nafion® Dryer.	51

10.3. Electronic Operation	53
10.3.1. Overview	53
10.3.2. The Relay PCA	54
10.3.2.1. Temperature Control of the Convection Oven.....	54
10.3.2.2. Oven Heaters AC Power Configuration	55
10.3.2.3. Status LED's	56
10.3.3. Motherboard	56
10.3.3.1. A to D Conversion.....	56
10.3.3.2. Sensor Inputs.....	56
10.3.4. Power Distribution.....	57
11. TROUBLESHOOTING & REPAIR	59
11.1. General Notes	59
11.2. Fault Diagnosis with Warning Messages	60
11.2.1. Fault Diagnosis with Test Functions	62
11.2.2. Relay Board Status LED's	64
11.3. Gas flow problems.....	65
11.4. Other Performance Problems	65
11.4.1. Unexplained drift.....	65
11.5. Subsystem Checkout	66
11.5.1. Relay Board	66
11.5.2. Motherboard	66
11.5.2.1. A/D Functions	66
11.6. Technical Assistance.....	67

LIST OF FIGURES

Figure 3-1: M300EU Internal Layout	5
Figure 3-2: M300EU Internal Gas Flow.....	6
Figure 3-3: M300EU Analog Output Connector	7
Figure 5-1: M300EU Internal Pneumatic Flow– Zero/Span Valves with Zero Scrubber (OPT 50A)	16
Figure 5-2: M300EU Internal Pneumatic Flow– Zero/Span Valves with IZS (OPT 51B)	17
Figure 5-3: M300EU Internal Pneumatic Flow– Zero/Span Valves with IZS & Shutoff Valve (OPT 51C).....	18
Figure 6-1: Typical Front Panel Display during A-REF Mode	21
Figure 6-2: Analog Output Connector Pin Out	23
Figure 10-1: M300EU Gas flow during Auto-Reference Measurements.....	49
Figure 10-2: Auto-Reference Measurement Cycle.....	50
Figure 10-3: Semi-Permeable Membrane Drying Process	51
Figure 10-4: M300EU Electronic Overview Block Diagram	53
Figure 10-5: M300EU Heating Control Block Diagram	54
Figure 10-6: M300EU Oven Heater Configuration Jumpers	55
Figure 10-7: M300EU Oven Heater Configuration Circuit.....	55
Figure 10-8: M300EU Distribution Block Diagram	57

LIST OF TABLES

Table 2-1: M300EU Basic Unit Specifications	3
Table 3-1: Analog Output Data Type Default Settings.....	7
Table 3-2: Analog Output Pin Outs	8
Table 3-3: Status Output Pin Assignments.....	8
Table 3-4: Possible Warning Messages at Start-Up.....	9
Table 5-1: Possible Warning Messages at Start-Up.....	15
Table 6-1: M300EU Operating Modes	20
Table 6-2: Test Functions Defined	22
Table 6-3: Test Functions Defined.....	32
Table 6-4: M300EU Diagnostic (DIAG) Submenus.....	33
Table 6-5: DIAG - Analog I/O Functions	34
Table 6-6: Test Channels Functions Available on the M300EU's Analog Output	38

Table 6-7:	M300EU Hessen GAS ID List.....	39
Table 6-8:	Default Hessen Status Bit Assignments	40
Table 7-1:	AUTOCAL Modes	42
Table 9-1:	M300EU Test Function Record	47
Table 10-1:	Auto-Reference Valve Operating States	51
Table 10-2:	Relay Board Status LED's	56
Table 11-1:	Warning Messages - Indicated Failures	60
Table 11-2:	Test Functions - Indicated Failures.....	62
Table 11-3:	Relay Board Status LED Failure Indications	64
Table 11-4:	Relay Board Control Devices.....	66

LIST OF APPENDICES

APPENDIX A – M300EU VERSION SPECIFIC SOFTWARE DOCUMENTATION

APPENDIX A-1: Model 300EU Software Menu Trees, Revision K.6

APPENDIX A-2: Model 300EU Setup Variables Available Via Serial I/O, Revision K.6

APPENDIX A-3: Model 300EU Warnings and Test Measurements via Serial I/O, Revision K.6

APPENDIX A-4: Model 300EU Signal I/O Definitions, Revision K.6

APPENDIX B – M300EU SPARE PARTS LIST

APPENDIX C - REPAIR QUESTIONNAIRE – M300EU

APPENDIX D - ELECTRONIC SCHEMATICS

USER NOTES:

USER NOTES:

1. INTRODUCTION

This addendum is based on the M300E/EM Operators Manual (P/N 04288). It is intended as a supplement to the M300E/EM manual (P/N 04288) and provides an overview of the instrument operation and specific details regarding those areas where the M300EU is different in design or operating method from the M300E.

In most ways the M300EU is identical to the M300E/EM in design and operation, therefore most of the basic set up information, operating instructions as well as calibration, maintenance, troubleshooting and repair methods are the same and can be found in the M300E/EM manual (P/N 04288).

1.1. REFERENCE NUMBERING CONVENTION

Unless otherwise specified, chapter, section, figure and table reference numbers referred to within this text are relative to this document.

- **EXAMPLE:** “Table 2-1” refers to the figure, within this document, labeled as 2-1.
- Additionally, in the electronic version(s) of this manual references internal to this document will be active links to that section, figure or table.

References to chapters, sections, figures and tables in the original document will be labeled as such and will not be an active link.

- **EXAMPLE:** “Figure 6.1 of the M300E/EM Operators Manual (P/N 04288)”.

1.2. M300EU OVERVIEW

NOTE

The information contained in this addendum is relevant to M300EU analyzers running: SOFTWARE REVISION K.6. Some or all of the information may not be applicable to earlier or later revisions of software.

The software revision your analyzer is running is displayed in the upper left-hand corner of the display any time the instrument is in SETUP mode.

The model 300EU is a close derivative of the M300E/EM CO Analyzer, however its higher sensitivity require some changes its design and operation.

The primary differences between the M300EU and the M300E/EM analyzers are:

- **INTERFERENT REJECTION:** Periodically the sample gas stream is routed through an internal CO scrubber allowing the instrument to make a measurement of the sample gas completely free of CO; the measurement made during this auto-reference period (**A-REF**) is subtracted from the sample concentration measurement. This corrects for instrument drift, ambient temperature changes and changing CO₂ levels in the sample gas.
- **OPERATING METHOD:** An additional operating mode is added allowing the user to manipulate several parameters associated with the **A-REF** measurement cycle.
- **SAMPLE GAS CONDITIONING:** A Nafion[®] drier is used to dry the sample and alleviate any effects from humidity changes in the sample gas.
- **IR OPTICS:** The objective and field mirrors on the optical bench are gold plated. This maximizes their reflectivity and increasing the amount of IR light reaching the detector and improving the optical bench's signal-to-noise performance.
- **PNEUMATIC OPERATION:** The flow rate is higher. It has a 1.8 LPM nominal flow rate. The flow sensor is rated to 6 LPM.
- **MECHANICAL DESIGN:** The optical bench is placed in a temperature-controlled, convection-heated oven. This dramatically reduces instrument noise and temperature related drift.

USER NOTES:

2. SPECIFICATIONS, APPROVALS AND WARRANTY

2.1. SPECIFICATIONS

Table 2-1: M300EU Basic Unit Specifications

Ranges	User selectable to any full scale range from 0-100 ppb to 0-100 ppm
Measurement Units	ppb, ppm, $\mu\text{g}/\text{m}^3$, mg/m^3 (user selectable)
Zero Noise	≤ 10 ppb RMS ^{1,6}
Span Noise	$< 0.5\%$ of reading RMS over 5 ppm ^{1,3}
Lower Detectable Limit	< 20 ppb ¹
Zero Drift (24 hours)	< 20 ppb ²
Zero Drift (7 days)	< 20 ppb ²
Span Drift (24 hours)	$< 0.5\%$ of reading ⁴
Span Drift (7 days)	$< 1\%$ of reading ^{2,4}
Linearity	Better than 1% of Range ⁵
Precision	0.5% reading ^{1,5}
Lag Time	< 10 sec ¹
Rise/Fall Time	< 30 sec to 95% ¹
Sample Flow Rate	1800 cm^3/min . $\pm 20\%$
Temperature Range	15 - 35°C operating
Humidity Range	0-95% RH, Non-Condensing
Voltage Coefficient	$< 0.05\%$ of reading per V
Dimensions (HxWxD)	7" x 17" x 23.5" (178 mm x 432 mm x 597 mm)
Weight	50 lb (22.7 kg)
AC Power	100V 50/60 Hz (3.25A), 115 V 60 Hz (3.0A), 220 – 240 V 50/60 Hz (2.5A)
Environmental Conditions	Installation Category (Over voltage Category) II Pollution Degree 2
Analog Outputs	Three (3) Outputs
Analog Output Ranges	100 mV, 1 V, 5 V, 10 V, 2-20 or 4-20 mA isolated current loop. All Ranges with 5% Under/Over Range
Analog Output Resolution	1 part in 4096 of selected full-scale voltage
Status Outputs	8 Status outputs from opto-isolators
Control Inputs	6 Control Inputs, 2 defined, 4 spare
I/O	One (1) RS-232; One (1) RS-485/RS-232/Ethernet Baud Rate : 300 - 115200
Certifications	CE: EN61010-1:90 + A1:92 + A2:95, EN61326 - Class A
¹ As defined by the USEPA ² At constant temperature and voltage ³ Or 10 ppb, whichever is greater ⁴ Or 10 ppb, whichever is greater ⁵ Above 1 ppm range, otherwise 20 ppb for lower ranges	

2.2. EPA EQUIVALENCY DESIGNATION

The M300EU has not been certified by the EPA as an equivalent method at the time of this writing however it is anticipated that the M300EU will qualify as Reference Method Number EQSA-0495-100 per 40 CFR Part 53 in the near future.

Therefore the information found in Section 2.2 of the M300E/EM Operators Manual (P/N 04288) is applicable to the M300EU with the following exception(s):

Range: Any range from 100 ppb to 100 ppm.

Ambient temperature range of 15 to 35°C.

Sample filter: Equipped with PTFE filter element in the external filter assembly.

Sample flow of 1800 ± 360 cm³/min at sea level.

Calibration valve options.

- a) Option 50A – Zero/Span Valves;
- b) Option 51B – Zero / Span Valves with Zero Scrubber.
- c) Option 51C – Zero / Span Valves with Zero Scrubber & Shut-off Valves

2.3. CE MARK COMPLIANCE

See Section 2.3 of the M300E/EM manual (P/N 04288)

2.4. WARRANTY

See Section 2.4 of the M300E/EM manual (P/N 04288)

USER NOTES:

3. GETTING STARTED

3.1. UNPACKING THE M300EU

Unpack the M300EU as per the directions in Section 3.1 of the M300E/EM manual (P/N 04288), with the exception that there are no shipping screws.

3.2. M300EU ANALYZER LAYOUT

The front panel of the M300EU is identical to that of the M300E/EM (see Figure 3-1 of the M300E/EM Operators Manual (P/N 04288)). The Rear Panel is also very similar to that of the M300E/EM, the only difference being that the instrument's particulate filter is mounted externally on the upper left side of the rear panel rather than internally as on the M300E/EM.

On the other hand, the internal layout of the M300EU is quite different from the M300E/EM. Most of these differences are related to the need to create a thermally insulated, convection-heated oven in which the optical bench temperature is raised and maintained at a high and very stable temperature. Additionally there is a multi-tube, high flow Nafion[®] dryer that removes moisture from the sample gas.

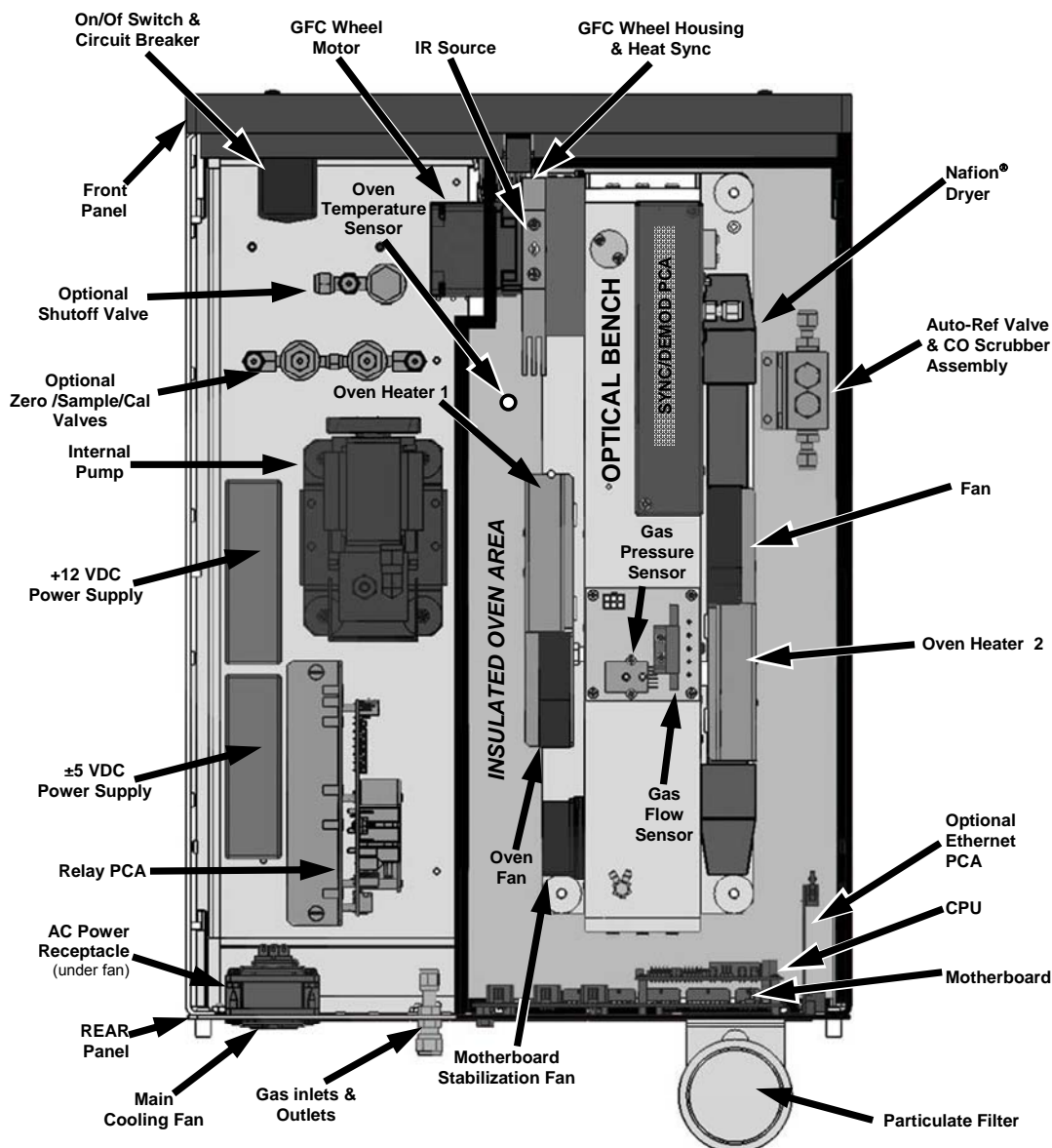

Figure 3-1: M300EU Internal Layout

The pneumatic flow of the M300EU is different from the M300E/EM in two ways:

- The addition of a high-flow multi-tube Nafion® dryer.
- An additional gas path that passes the sample gas through a CO scrubber used during the auto-reference cycle.

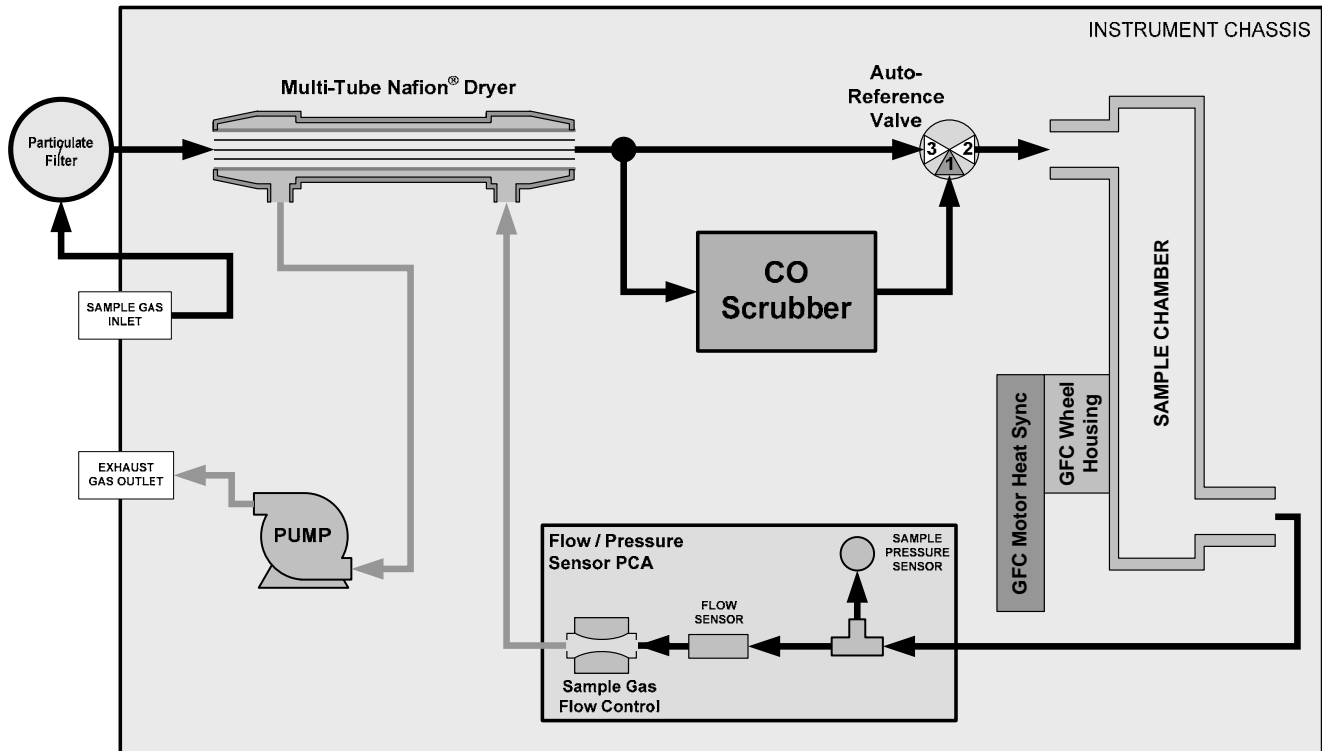

Figure 3-2: M300EU Internal Gas Flow

3.3. ELECTRICAL CONNECTIONS

The information found in Section 3.1.2 of the M300E/EM Operators Manual (P/N 04288) is applicable to the M300EU with the following exceptions.

3.3.1. POWER CONNECTION

The information found in Section 3.1.2.1 of the M300E/EM manual (P/N 04288) is correct for the M300EU.

3.3.2. ANALOG OUTPUT Connections

The analog outputs for the M300EU are different from those of the M300E/EM. Unlike the M300E/EM which can include options for measuring both O₂ and CO, the M300EU is a single gas analyzer (CO) and therefore does not require the fully configurable version of the analog outputs. The following information replaces that found in Section 3.1.2.2 of the M300E/EM Operators Manual (P/N 04288).

The M300EU is equipped with several analog output channels accessible through a connector on the back panel of the instrument.

- Channels **A1** and **A2** output a signal that is proportional to the CO concentration of the sample gas.
 - The default analog output voltage setting of these channels is 0 to 5 VDC with a reporting range of 0 to 500 ppb.
 - An optional Current Loop output is available for each.
- The output labeled **A4** is special. It can be set by the user to output any one a variety of diagnostic test functions.
 - The default analog output voltage setting of these channels is also 0 to 5 VDC.
 - See Section 6.2.2 for a list of available functions.
 - There is **NO** optional Current Loop output is available for Channel **A4**.

The following table lists the default settings for each of these channels.

Table 3-1: Analog Output Data Type Default Settings

PARAMETER	CHANNEL DEFAULT SETTING			
	A1	A2	A3	A4 ¹
DATA TYPE ¹	CONC1	CONC2	Not Available	TEST CHANNEL
RANGE	0 – 5 VDC ²			
OVERRANGE	ON			
REC OFS	0 mVDC			
AUTO CAL.	ON			
CALIBRATED	NO			
OUTPUT	ON			

¹ See Table A-6 of M300E/EM Appendix A for definitions of these iDAS data types
² Optional current loop outputs are available for analog output channels **A1** & **A2**.

To access these signals attach a strip chart recorder and/or data-logger to the appropriate analog output connections on the rear panel of the analyzer. Pin-outs for the analog output connector are:

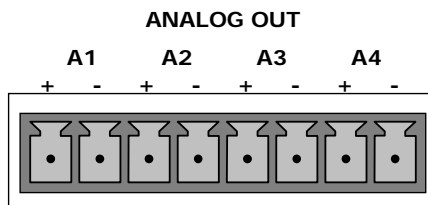

Figure 3-3: M300EU Analog Output Connector

Table 3-2: Analog Output Pin Outs

Pin	Analog Output	Standard Voltage Output	Current Loop Option
1	A1	V Out	I Out +
2		Ground	I Out -
3	A2	V Out	I Out +
4		Ground	I Out -
5	A3	NOT USED	
6		NOT USED	
7	A4	V Out	Not Available
8		Ground	Not Available

3.3.3. CONNECTING THE STATUS OUTPUTS

The information found in Section 3.1.2.3 is correct with the following exception:

Table 3-3: Status Output Pin Assignments

Output #	Status Definition	Condition
1	SYSTEM OK	On if no faults are present.
2	CONC VALID	On if CO concentration measurement is valid. If the CO concentration measurement is invalid, this bit is OFF.
3	HIGH RANGE	On if unit is in high range of DUAL or AUTO Range Modes.
4	ZERO CAL	On whenever the instruments ZERO point is being calibrated.
5	SPAN CAL	On whenever the instruments SPAN point is being calibrated.
6	DIAG MODE	On whenever the instrument is in DIAGNOSTIC mode.
7	A-REF	On whenever the instrument in is A-REF mode.
8	SPARE	
D	EMITTER BUSS	The emitters of the transistors on pins 1-8 are bussed together.
+	DC POWER	+ 5 VDC
	Digital Ground	The ground level from the analyzer's internal DC Power Supplies.

3.4. INITIAL OPERATION OF THE M300EU

NOTE

The analyzer's cover must be installed and securely fastened to ensure that the convection oven portion of the internal layout is capable of properly creating and controlling temperatures of the analyzer's optical bench.

3.4.1. STARTUP AND WARM UP OF THE M300EU

The process for starting and warming up the M300EU is identical to that described in Sections 3.2.1 and 3.2.2 of the M300E/EM Operators Manual (P/N 04288) except:

- It is best to allow the M300EU to operate uninterrupted for at least 2 hours to allow the temperature of all areas of the convection oven area to equalize.

3.4.2. WARNING MESSAGES

The information found in Section 3.2.3 of the M300E/EM Operators Manual (P/N 04288) is applicable to the M300EU with the following exception(s)

Table 3-4: Possible Warning Messages at Start-Up

MESSAGE	MEANING
ANALOG CAL WARNING	The instrument's A/D circuitry or one of its analog outputs is not calibrated.
AZERO WARN 1.001	Auto-reference ratio below the specified limits.
BENCH TEMP WARNING	Optical bench temperature is outside the specified limits.
BOX TEMP2 WARNING	The temperature inside the M300EU chassis is outside the specified limits (Replaces BOX TEMP WARNING)
CANNOT DYN SPAN	Remote span calibration failed while the dynamic span feature was set to turned on
CANNOT DYN ZERO	Remote zero calibration failed while the dynamic zero feature was set to turned on
CONFIG INITIALIZED	Configuration was reset to factory defaults or was erased.
DATA INITIALIZED	iDAS data storage was erased.
FRONT PANEL WARN	Firmware is unable to communicate with the front panel.
OVEN TEMP WARNING	The temperature of the insulated convection oven area of the analyzer is outside of the specified limits.
PHOTO TEMP WARNING	Photometer temperature outside of warning limits specified by PHOTO_TEMP_SET variable.
REAR BOARD NOT DET	The CPU is unable to communicate with the motherboard.
RELAY BOARD WARN	The firmware is unable to communicate with the relay board.
SAMPLE FLOW WARN	The flow rate of the sample gas is outside the specified limits.
SAMPLE PRESS WARN	Sample pressure outside of operational parameters.
SAMPLE TEMP WARN	The temperature of the sample gas is outside the specified limits.
SOURCE WARNING	The IR source may be faulty.
SYSTEM RESET	The computer was rebooted.
WHEEL TEMP WARNING	The Gas Filter Correlation wheel temperature is outside the specified limits.

3.4.3. FUNCTIONAL CHECK

The information found in Section 3.2.4 of the M300E/EM Operators Manual (P/N 04288) regarding performing an initial functional check of the analyzer is applicable to the M300EU with the following exception(s).

The Test functions available from the front panel of the M300EU are:

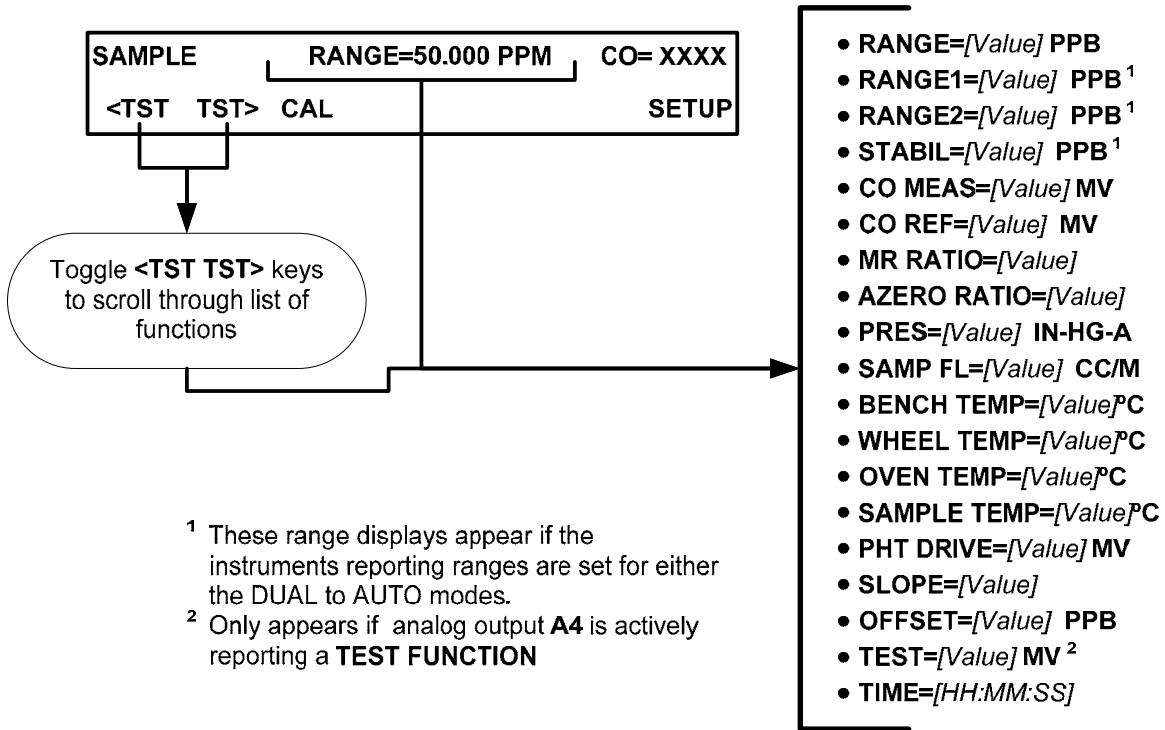

¹ These range displays appear if the instruments reporting ranges are set for either the DUAL to AUTO modes.

² Only appears if analog output **A4** is actively reporting a **TEST FUNCTION**

3.5. INITIAL CALIBRATION

3.5.1. PRE-CALIBRATION STABILIZATION

Before initially calibrating the M300EU it must be allowed to operate for a minimum of 12 hours.

After this stabilization period is complete and just prior to performing the initial calibration, manually initiate an auto-reference measurement by following the instructions in Section 6.4.

3.5.2. BASIC CO CALIBRATION SETUP

NOTE

The following procedure assumes that the instrument does not have any of the available Zero/Span Valve Options installed.

To perform the following calibration you must have sources for zero air and span gas available for input into the sample port on the back of the analyzer. See Section 3.1.3 of the M300E/EM Operators Manual (P/N 04288) for instructions for connecting these gas sources.

NOTE

All Gas lines should be PTFE (Teflon), FEP, glass, stainless steel or brass

3.5.2.1. Calibration Gases

The information found in Section 3.1.3.2 of the M300E/EM Operators Manual (P/N 04288) is applicable to the M300EU with the following exception:

ZERO AIR

A gas that is similar in chemical composition to the earth's atmosphere but scrubbed of all components that might affect the analyzers readings, in this case CO and water vapor.

For the M300EU this gas **MUST** include at least 5% O₂ (required for the proper operation of the analyzer's CO scrubber).

For analyzers without an IZS or external zero air scrubber option, a zero air generator such as the Teledyne Instruments Model 701 can be used.

NOTE

The zero air generator **MUST be equipped with a hydrocarbon (HC) & CO scrubber option.**

For the Teledyne Instruments M701, this is Option 2B

3.5.3. BASIC CO CALIBRATION PROCEDURE

The initial calibration should be carried out using the same reporting range set up as used during the analyzer's factory calibration. This will allow you to compare your calibration results to the factory calibration as listed on the *Final Test and Validation Data Sheet*.

Because the M300EU's analog output setup differs from that of the M300E/EM and because the M300EU cannot have be modified to include the optional CO₂ or O₂ sensor packages, there are some minor differences in the initial Calibration procedure as described in Section 3.3 of the M300E/EM Operators Manual (P/N 04288).

These are:

- **STEP 1 - SET LIMITS:**
 - Reporting Range Limit should be set to 50.000 ppm.
- **STEP 2 – DILUTION RATIO:**
 - Ignore this step
- **STEP 3 – SET CO SPAN GAS CONCENTRATION**
 - The CO span gas concentration should be 40.000 ppm
- **STEP 4 – ZERO/SPAN CALIBRATION**
 - Set the display to show the **STABILITY** test function.
 - There is no **GAS TO CAL** step because the M300EU cannot be modified to include the O₂ and CO₂ sensor packages.

Ignore Sections 3.3.2 and 3.3.3 of the M300E/EM Operators Manual (P/N 04288) since they relate to sensor options not available on the M300EU.

USER NOTES:

4. FREQUENTLY ASKED QUESTIONS & GLOSSARY

The information found in Chapter 4 of the M300E/EM Operators Manual (P/N 04288) is applicable to the M300EU.

USER NOTES:

USER NOTES:

5. OPTIONAL HARDWARE AND SOFTWARE

The following table lists the optional hardware is available for the M300Ex family of analyzers. There are no additional options available for the M300EU that are not also available for the M300E/EM.

For descriptions of these options and their use please see Chapter 5 of the M300E/EM Operators Manual (P/N 04288).

Table 5-1: Possible Warning Messages at Start-Up

OPTION NO.	DESCRIPTION	300E	300EM	300EU
PUMP PACKS				
10A	External Pump 115V/60Hz	X	X	X
10B	External Pump 220V/50Hz	X	X	X
10C	External Pump 220V/60Hz	X	X	X
10D	External Pump 100V/50Hz	X	X	X
10E	External Pump 100V/60Hz	X	X	X
13	High Voltage Internal Pump 240V/50Hz (E Series non-NOx internal pump)	X	X	
RACK MOUNTING				
20A	Rack Mount with Chassis Slides - 26"	X	X	X
20B	Rack Mount with Chassis Slides - 24"	X	X	X
21	Rack Mount, Ears only (No Slides)	X	X	X
23	Rack Mount for External Pump Pack (No Slides)	X	X	X
29	Carrying Handle (Strap)	X	X	X
RANGE & OUTPUT OPTIONS				
41	Isolated 0-20 or 4-20 mA output	X	X	X
EXPENDABLES KITS & SPARES				
42A	Expendable Kit for one year operation	X	X	X
VALVES AND IZS				
50A	Zero/Span Valves	X	X	X
51B	Zero / Span Valves with Zero Scrubber	X	X	X
51C	Zero / Span Valves with Zero Scrubber & Shut-off Valves	X	X	X
COMMUNICATIONS				
60A	RS232 Cable DB9F to DB25M	X	X	X
60B	RS232 Cable DB9F to DB9F	X	X	X
60C	CATS, 7 (2m) RJ-45	X	X	X
62	RS232 Multidrop	X	X	X
63A	Ethernet	X	X	X
63C	Multidrop/Ethernet Combo	X	X	X
SECOND SENSORS				
65A	Paramagnetic O2 Sensor	X	X	
67A	CO2 Sensor 20%		X	
67B	CO2 Sensor 5%		X	
67C	CO2 Sensor 2000 PPM	X		
MANUALS				
70A	Additional Manual	X	X	X
70B	Manual on CD	X	X	X

For assistance with ordering these options, please contact the Sales department of Teledyne – Advanced Pollution Instruments at:

TOLL-FREE: 800-324-5190
 FAX: 858-657-9816
 TEL: 858-657-9800
 E-MAIL: api-sales@teledyne.com
 WEB SITE: www.teledyne-api.com

5.1. CALIBRATION VALVE OPTIONS FOR THE M300EU

The various valve options available on the M300EU are implemented in the same manner as described in the corresponding sections of the M300E/EM Operators Manual (P/N 04288) with the following exception(s).

5.1.1. ZERO SPAN VALVES (OPT 50A)

Because of the addition of the auto-reference gas path and the multi-tube Nafion® dryer, the internal pneumatics gas flow of the M300EU is somewhat different from the M300E/EM. Otherwise, the information found in Section 5.4.3 of the M300E/EM Operators Manual (P/N 04288) is applicable to the M300EU.

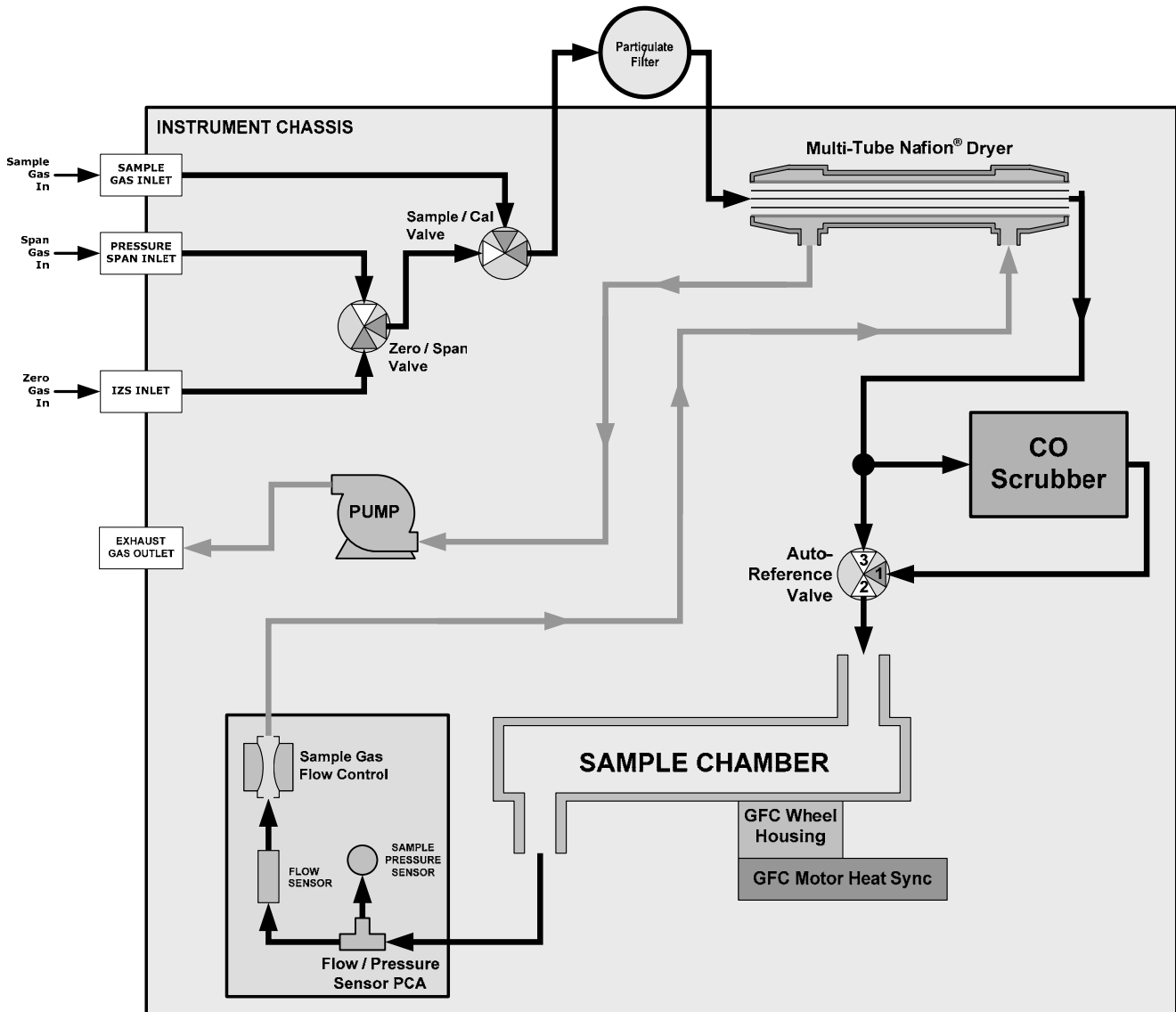

Figure 5-1: M300EU Internal Pneumatic Flow– Zero/Span Valves (OPT 50A)

5.1.2. ZERO SPAN VALVES WITH IZS (OPT 51B)

Because of the addition of the auto-reference gas path and the multi-tube Nafion® dryer, the internal pneumatics gas flow of the M300EU is somewhat different from the M300E/EM. Otherwise, the information found in Section 5.4.4 of the M300E/EM Operators Manual (P/N 04288) is applicable to the M300EU.

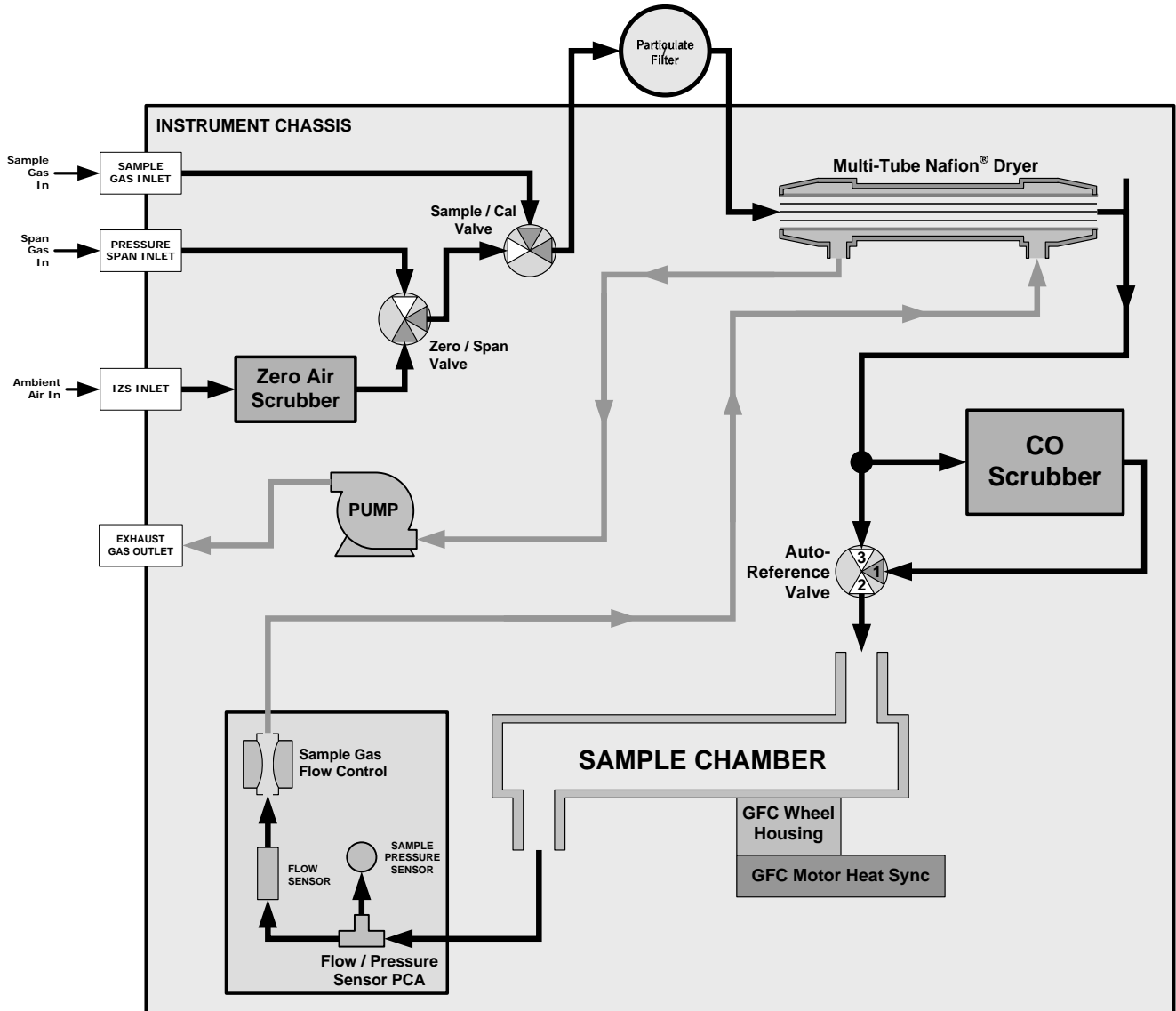

Figure 5-2: M300EU Internal Pneumatic Flow– Zero/Span Valves with IZS (OPT 51B)

5.1.3. Zero Span Valves with IZS and Shutoff VALVE (OPT 51B)

Because of the addition of the auto-reference gas path and the multi-tube Nafion® dryer, the internal pneumatics gas flow of the M300EU is somewhat different from the M300E/EM. Otherwise, the information found in Section 5.4.4 of the M300E/EM Operators Manual (P/N 04288) is applicable to the M300EU.

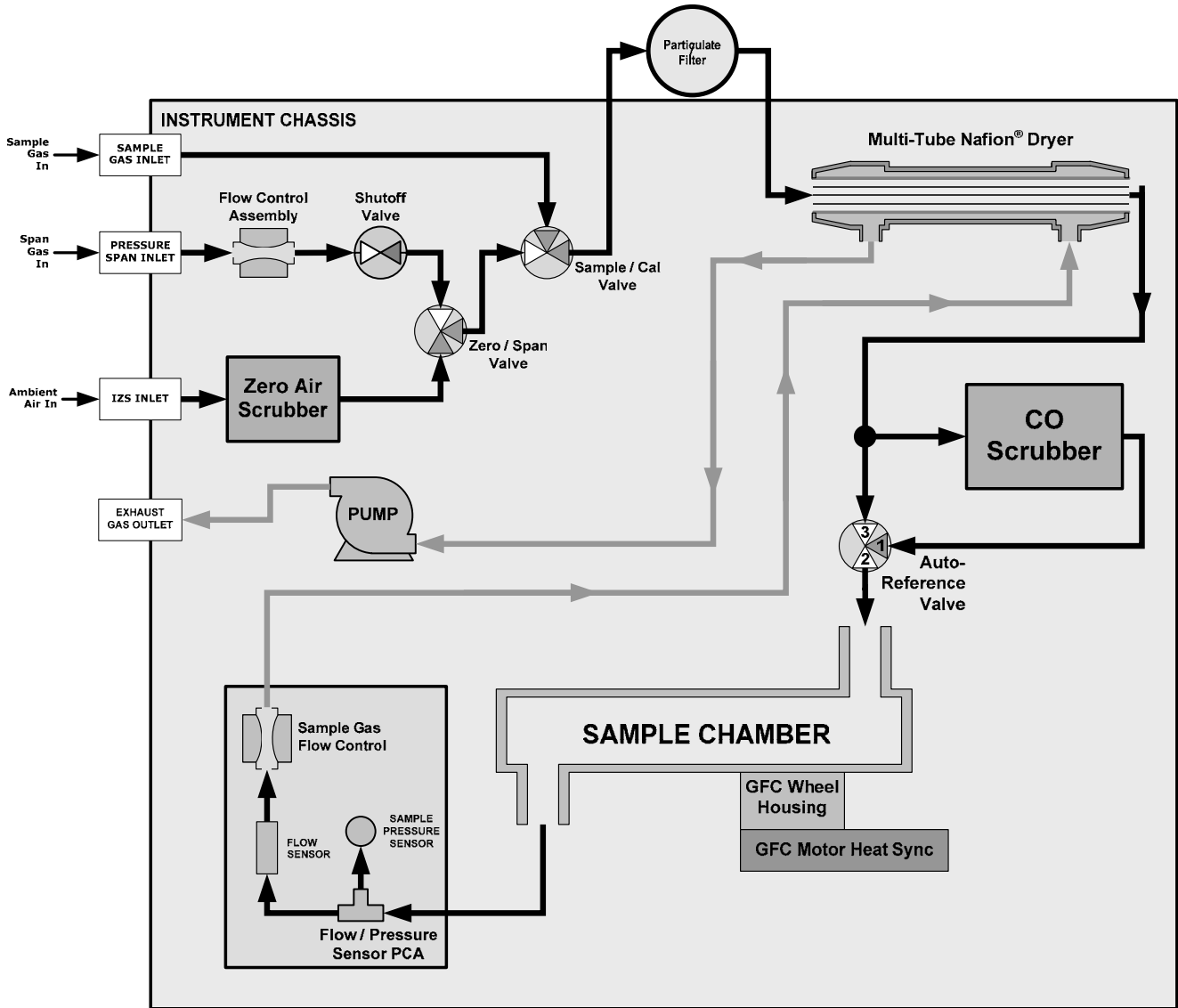

Figure 5-3: M300EU Internal Pneumatic Flow– Zero/Span Valves with IZS & Shutoff Valve (OPT 51C)

USER NOTES:

6. M300EU OPERATING INSTRUCTIONS

6.1. SUMMARY OF DIFFERENCES BETWEEN OPERATING THE M300EU AND THE M300E/EM ANALYZERS.

For the most part the operation instruction for the M300EU are the same as those described in Chapter 6 of the M300E/EM manual (P/N 04288) with the following exceptions:

- There are several additional Test functions related to the optical bench's convection oven and the **A-REF** cycle (see Section 6.2.2).
- There is an additional warning message related to the optical bench's convection oven (see Section 3.4.2)
- There is an additional operating mode, **AREF**, which can be used to force the instrument to make an auto-reference measurement and calculation.
- There are several additional iDAS trigger events and parameters (see Appendix A of this addendum).
- The reporting range setup and configuration of the A1 and A2 analog outputs is different (see Section 6.3).
- The optional O₂ and CO₂ sensor packages available for the M300E/EM are not available on the M300EU. Ignore all references to these in the M300E/EM Operators Manual (P/N 04288) when operating the M300EU.
- The set of available VARS is different (see Section 6.5).
- The set of submenus available under the **DIAG** menu is slightly different (see Section 6.6).
- The set of signals available under the **DIAG → SIGNAL I/O** submenu is different (see Appendix A of this addendum).
- Because of the difference in how the analog output ranges are implemented between the M300E/EM and the M300EU, there are some differences in **DIAG → ANALOG I/O CONFIGURATION** submenu (see Section 6.7.1).
- There are no alarm outputs available on the M300EU. Ignore Section 6.14 of the M300E/EM Operators Manual (P/N 04288).
- There is an additional **STATUS OUTPUT** related to the **A-REF** cycle (see Section 3.3.3).
- The default Hessen protocol gas ID and status flag list is different from that of the M300E/EM (see Section 6.7.4).

6.2. OPERATING MODES

The information found in Section 6.1 of the M300E/EM Operators Manual (P/N 04288) is applicable to the M300EU with the following exception(s).

The following table supersedes Table 6-2 of the M300E/EM Operators Manual (P/N 04288).

Table 6-1: M300EU Operating Modes

MODE	MEANING
A-REF	The analyzer is currently recording values for CO MEAS and CO ref, while the sample gas stream is being routed through the CO scrubber of the auto-reference gas path.
DIAG	One of the analyzer's diagnostic modes is being utilized.
M-P CAL	This is the basic, multi-point calibration mode of the instrument and is activated by pressing the CAL key.
SAMPLE	Sampling normally, flashing indicates adaptive filter is on.
SAMPLE A	Indicates that unit is in SAMPLE Mode and AUTOCAL feature is activated.
SETUP¹	SETUP mode is being used to configure the analyzer (CO sampling will continue during this process as well as data collection and output).
SPAN CAL A²	Unit is performing span cal procedure initiated automatically by the analyzer's AUTOCAL feature.
SPAN CAL M²	Unit is performing span cal procedure initiated manually by the user.
SPAN CAL R²	Unit is performing span cal procedure initiated remotely via the RS-232, RS-4485 or digital i/o control inputs.
ZERO CAL A²	Unit is performing zero cal procedure initiated automatically by the analyzer's AUTOCAL feature.
ZERO CAL M²	Unit is performing zero cal procedure initiated manually by the user.
ZERO CAL R²	Unit is performing zero cal procedure initiated remotely via the RS-232, RS-4485 or digital I/O control inputs.
¹ The revision of the Teledyne Instruments software installed in this analyzer will be displayed following the word SETUP . E.g. " SETUP G.5 "	
² The various CAL modes allow calibration of the analyzer. Because of their importance, these modes are described separately in Chapter 7 of the M300E/EM Operators Manual (P/N 04288).	

6.2.1. AUTO-REFERENCE MODE (AREF)

One of the most significant differences between the M300E/EM and the M300EU analyzers is the auto-reference measurement feature. In this mode, the analyzer makes special measurements and calculations that are applied to the CO concentration calculation to dramatically improve interferent rejection as well as compensate for changes in ambient temperature of the sample gas and age related drift of the optical bench components (see Section 10.1.1 for detailed information about how and when this **A-REF** feature occurs).

When in **A-REF** mode, the analyzer:

- Freezes the CO concentration reading displayed on the front panel and output via the analog outputs or COM Ports.
- Displays the Message **AUTO-REF** in the mode field of the analyzer's front panel.
- Sets the **A-REF** status output (pin-7 on the status output connector) to high.

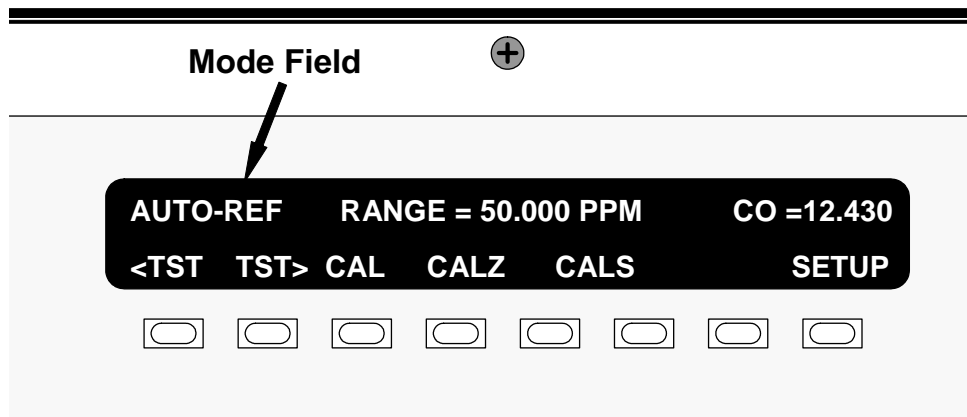

Figure 6-1: Typical Front Panel Display during A-REF Mode

NOTE:

Initiating a calibration through either the keyboard, the COMM ports or digital control inputs terminates the A-REF mode.

Also, when the instrument is in calibration mode, the A-REF mode is suppressed until the instrument exits calibration mode.

See Section 6.4 for information about changing the **A-REF** cycle time or manually initiating an auto-reference measurement.

6.2.2. TEST FUNCTIONS

The information found in Section 6.2.1 of the M300E/EM Operators Manual (P/N 04288) is applicable to the M300EU with the following exception(s):

- The following table supersedes Table 6-2 of the M300E/EM Operators Manual (P/N 04288).

Table 6-2: Test Functions Defined

Parameter	Display Title	Units	Meaning
RANGE -- RANGE1 RANGE2	RANGE	PPB, PPM UGM, MGM	The full-scale limit at which the output range of the analyzer's Analog Outputs is currently set. <ul style="list-style-type: none"> THIS IS NOT the Physical Range of the instrument. See Section 6.3.2 for more information. If DUAL or AUTO Range modes have been selected, two RANGE functions will appear, one for each range.
Stability	STABIL	PPB, PPM UGM, MGM	Standard deviation of CO concentration readings. Data points are recorded every ten seconds using the last 25 data points. This function can be reset to show O ₂ or CO ₂ stability in instruments with those sensor options installed.
CO Measure	MEAS	MV	The demodulated, peak IR detector output during the measure portion of the CFG Wheel cycle.
CO Reference	REF	MV	The demodulated, peak IR detector output during the reference portion of the CFG wheel cycle.
Measurement / Reference Ratio	MR Ratio	-	The result of CO MEAS divided by CO REF based on readings taken during the normal sample measurement portion of the A-REF cycle. This ratio is the primary value used to compute CO concentration. The value displayed is not linearized.
Auto-Reference Ratio	AZERO RATIO	-	The result of CO MEAS divided by CO REF based on readings taken during the zero-reference portion of the A-REF cycle. This ratio is the used to compute a reference correction factor for computing the CO concentration. The value displayed is not linearized.
Sample Pressure	PRES	In-Hg-A	The absolute pressure of the Sample gas as measured by a pressure sensor located inside the sample chamber.
Sample Flow	SAMPLE FL	cm ³ /min	Sample mass flow rate as measured by the flow rate sensor in the sample gas stream,
Sample Temperature	SAMP TEMP	°C	The temperature of the gas inside the sample chamber.
Bench Temperature	BENCH TEMP	°C	Optical bench temperature.
Wheel Temperature	WHEEL TEMP	°C	GFC wheel temperature.
Box Temperature	BOX TEMP	°C	The temperature inside the analyzer chassis.
Oven Temperature	OVEN TEMP²	°C	The current temperature of the circulating air inside the M300EU's convection oven area.
Photo-detector Temp. Control Voltage	PHT DRIVE	mV	The drive voltage being supplied to the thermoelectric coolers of the IR photo-detector by the sync/demod Board.
Slope	SLOPE	-	The sensitivity of the instrument as calculated during the last calibration activity. The SLOPE parameter is used to set the span calibration point of the analyzer.
Offset	OFFSET	-	The overall offset of the instrument as calculated during the last calibration activity. The OFFSET parameter is used to set the zero point of the analyzer response.
Test Channel Output	TEST	mV	The raw voltage being output on the analyzer's A4 analog output. Only appears when the test channel is assigned a function.
Current Time	TIME	-	The current time. This is used to create a time stamp on iDAS readings, and by the AUTOCAL feature to trigger calibration events.

6.3. SETUP → RNGE: ANALOG OUTPUT REPORTING RANGE CONFIGURATION

6.3.1. PHYSICAL RANGE VERSUS ANALOG OUTPUT REPORTING RANGES

Functionally, the M300EU analyzer has one hardware “physical range” that is capable of determining CO concentrations between 0 ppb and 100,000 ppb. This architecture improves reliability and accuracy by avoiding the need for extra, switchable, gain-amplification circuitry. Once properly calibrated, the analyzer’s front panel will accurately report concentrations along the entire span of its physical range. M300EU analyzer’s physical range can create data resolution problems for most analog recording devices. For example, in an application where the expected concentration of CO is typically less than 1000 ppb, the full scale of expected values is only 1% of the instrument’s 100,000 ppb physical range. Unmodified, the corresponding output signal would also be recorded across only 1% of the range of the recording device.

The M300EU solves this problem by allowing the user to select a scaled reporting range for the analog outputs that only includes that portion of the physical range relevant to the specific application.

NOTE

Only the reporting range of the analog outputs is scaled.

Both the iDAS values stored in the CPU’s memory and the concentration values reported on the front panel are unaffected by the settings chosen for the reporting range(s) of the instrument.

6.3.2. ANALOG OUTPUT RANGES FOR CO CONCENTRATION

The analyzer has two active analog output signals related to CO concentration that are accessible through a connector on the rear panel.

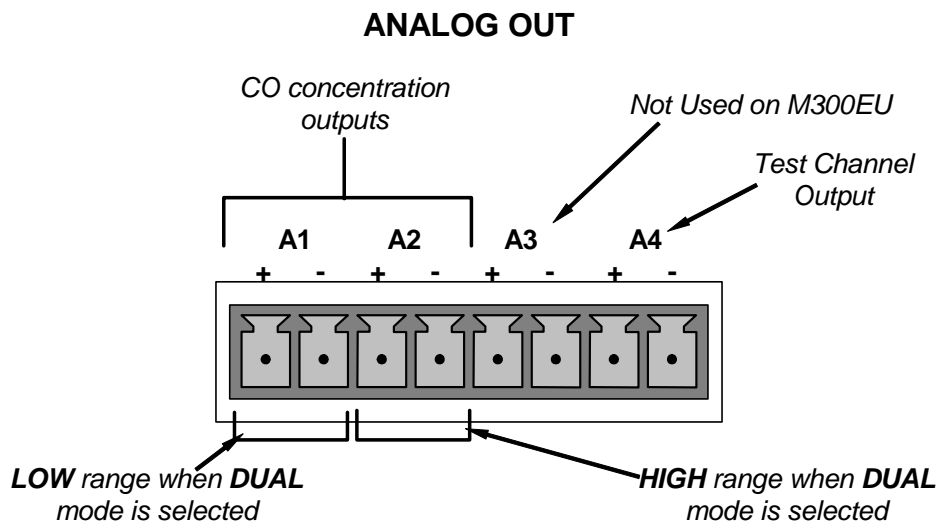

Figure 6-2: Analog Output Connector Pin Out

The **A1** and **A2** channels output a signal that is proportional to the CO concentration of the sample gas. They can be configured:

- With independent reporting ranges reporting a “single” output signal (**SNGL** Mode, see Section 6.3.3) or
- Be to operate completely independently (**DUAL** mode, see Section 6.3.4). In this mode the user can set the measure span and signal scale of each output in a variety of combinations (but not the units of measure).

EXAMPLE:

A1 OUTPUT: Output Signal = 0-5 VDC representing 0-1000 ppb concentration values

A2 OUTPUT: Output Signal = 0 – 10 VDC representing 0-500 ppb concentration values.

- Or to automatically switch between the two ranges dynamically as the concentration value fluctuates (**AUTO** modes, see Section 6.3.5).

Both the **A1** and **A2** outputs can be:

- Configured full scale outputs of: 0 - 0.1 VDC; 0 - 1VDC; 0 - 5VDC or; 0 - 10VDC.
- Equipped with optional 0-20 mA DC current loop drivers and configured for any current output within that range (e.g. 0-20, 2-20, 4-20, etc.).

The user may also add a signal offset independently to each output (see Section 6.7.1) to match the electronic input requirements of the recorder or data logger to which the output is connected.

DEFAULT SETTINGS

The default setting for these the reporting ranges of the analog output channels **A1** and **A2** are:

- SNGL mode
- 0 to 500.0 ppb
- 0 to 5 VDC

Reporting range span may be viewed via the front panel by viewing the **RANGE** test function. If the **DUAL** or **AUTO** modes are selected, the **RANGE** test function will be replaced by two separate functions, **RANGE1** & **RANGE2**. Reporting range status is also available as output via the external digital I/O status bits.

NOTE

Upper span limit setting for the individual range modes are shared. Resetting the span limit in one mode also resets the span limit for the corresponding range in the other modes as follows:

<u>SNGL</u> Range	↔	<u>DUAL</u> Range1 (Low) Range2 (Hi)	↔	<u>AUTO</u> Low Range High Range
----------------------	---	--	---	--

6.3.3. RNGE → MODE → SNGL: CONFIGURING THE M300EU ANALYZER FOR SINGLE RANGE MODE

The single range mode sets a single maximum range for the both the **A1** and **A2** analog outputs. If the single range is selected both outputs are slaved together and will represent the same reporting range span (e.g. 0-50 ppm), however their electronic signal levels may be configured for different ranges (e.g. 0-10 VDC vs. 0-.1 VDC).

This Reporting range can be set to any value between 0.1 ppb and 10,000 ppb. To select **SINGLE** range mode and set the upper limit of the reporting range, press:

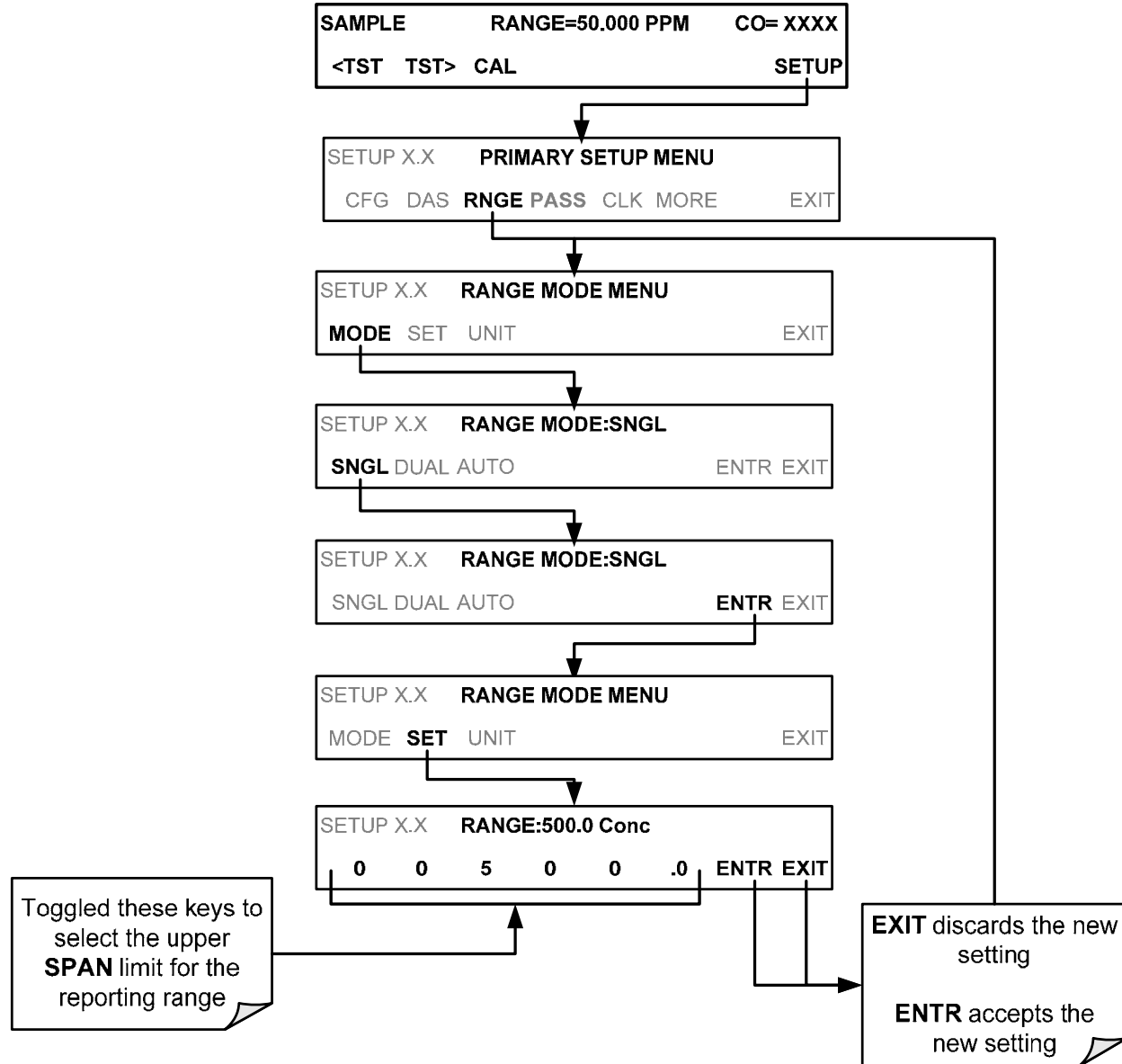

NOTE
 This is the default reporting range mode for the analyzer.

6.3.4. RNGE → MODE → DUAL: CONFIGURING THE M300EU ANALYZER FOR DUAL RANGE MODE

DUAL range mode allows the **A1** and **A2** outputs to be configured with separate reporting range spans as well as separate electronic signal levels. The analyzer software calls these two ranges **LOW** and **HI**.

- The **LOW** range setting corresponds with the analog output labeled **A1** on the rear panel of the instrument and is viewable via the test function **RANGE 1**.
- The **HIGH** range setting corresponds with the **A2** output and is viewable via the test function **RANGE 2**.
- While the software labels these two ranges as **LOW** and **HI**, when in **DUAL** mode their upper limits need not conform to that convention. The upper span limit of the **LOW/RANGE1** can be a higher number than that of **HI/RANGE 2**

To set the ranges press following keystroke sequence:

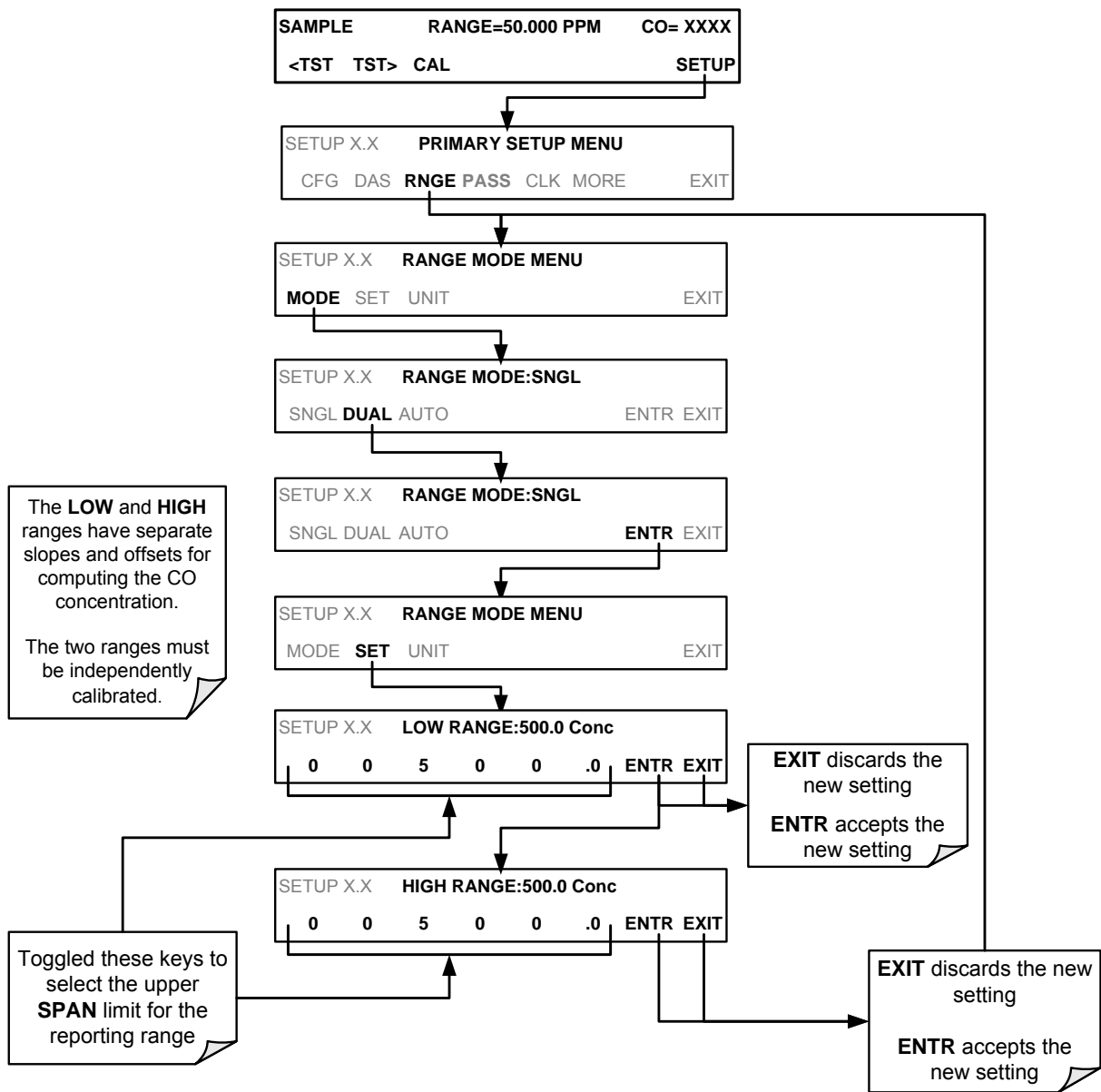

6.3.6. SETUP → RNGE → UNIT: SETTING THE REPORTING RANGE UNIT TYPE

The M300EU can display concentrations in ppb, ppm, ug/m³, mg/m³ units. Changing units affects all of the COM port values, and all of the display values for all reporting ranges. To change the units of measure press:

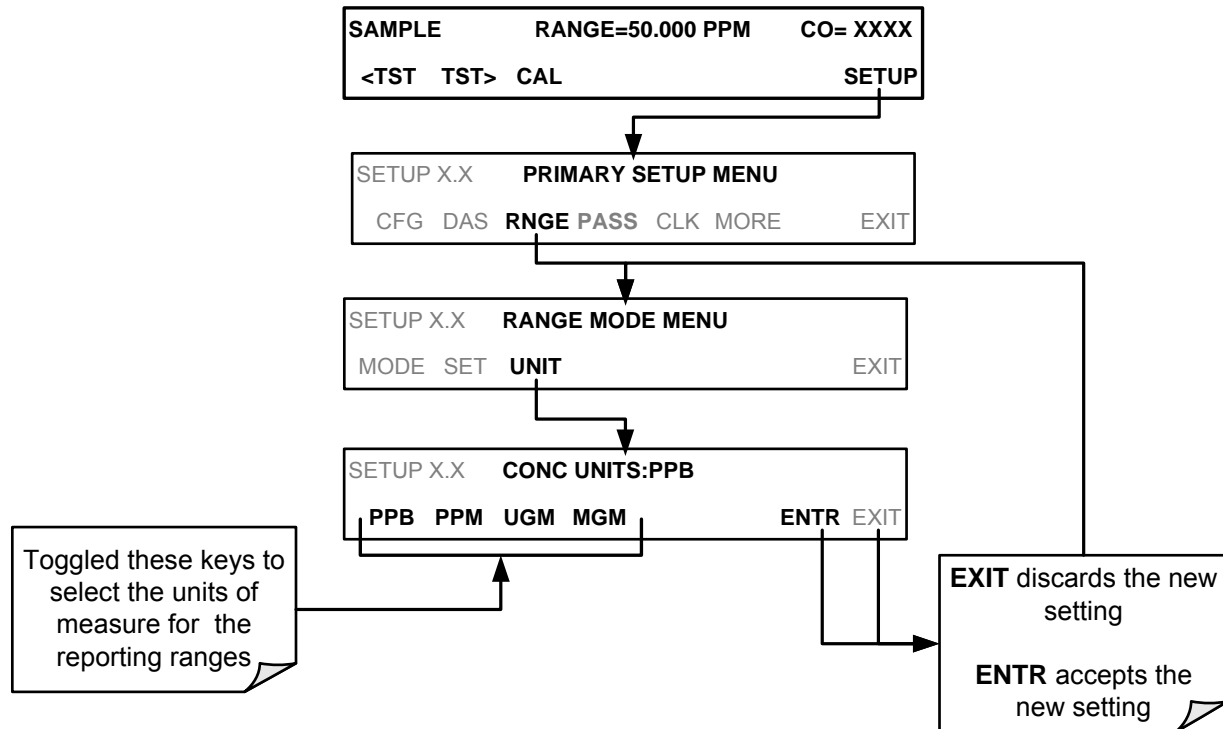

NOTE

Concentrations displayed in mg/m³ and ug/m³ use 0°C , 760 mmHg for Standard Temperature and Pressure (STP).

Consult your local regulations for the STP used by your agency.

NOTE

Once the units of measurement have been changed, the unit **MUST** be recalibrated, as the “expected span values” previously in effect will no longer be valid.

Simply entering new expected span values without running the entire calibration routine is not sufficient.

The following equations give approximate conversions between volume/volume units and weight/volume units:

$$\text{CO ppb} \times 1.25 = \text{CO ug/m}^3$$

$$\text{CO ppm} \times 1.25 = \text{CO mg/m}^3$$

6.4. SETUP → MORE → AREF: CONFIGURING AND PERFORMING AUTO-REFERENCE MEASUREMENTS

6.4.1. ADJUSTING THE A-REF MODE CYCLE TIME

The auto-reference measurement feature is initiated by the M300EU at regular intervals (see Section 10.1.1). It is triggered by the timer feature of the analyzers ACAL system, which uses the instrument's internal clock.

All M300EU analyzers are shipped from the factory the **ACAL** system enabled (even on instruments without calibration valve options installed) and the first **ACAL** sequence already programmed and activated with the **DELTA TIME** parameter set for 4 hours (for a more detailed discussion of the ACAL system see Section 7.7 of the M300E/EM Operators Manual).

This interval time can be changed to fit the specific application in which the M300EU is being used. To change the A0REF interval, press:

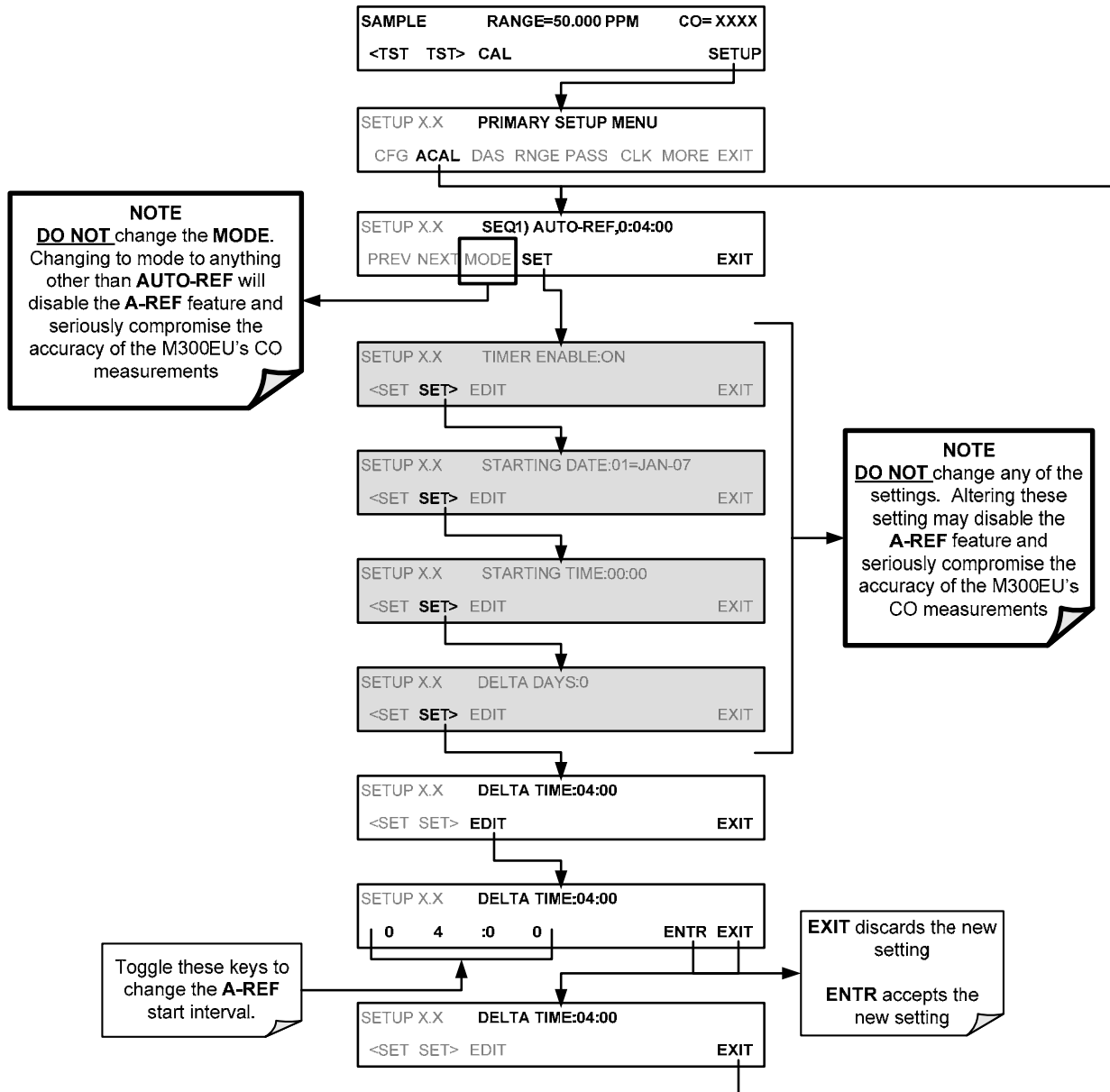

6.4.2. FORCING AN AUTO-REFERENCE MEASUREMENT

Sometimes it is advisable to perform an auto-reference measurement at other times such as just before calibrating the analyzer.

To manually start an auto-reference measurement cycle, press:

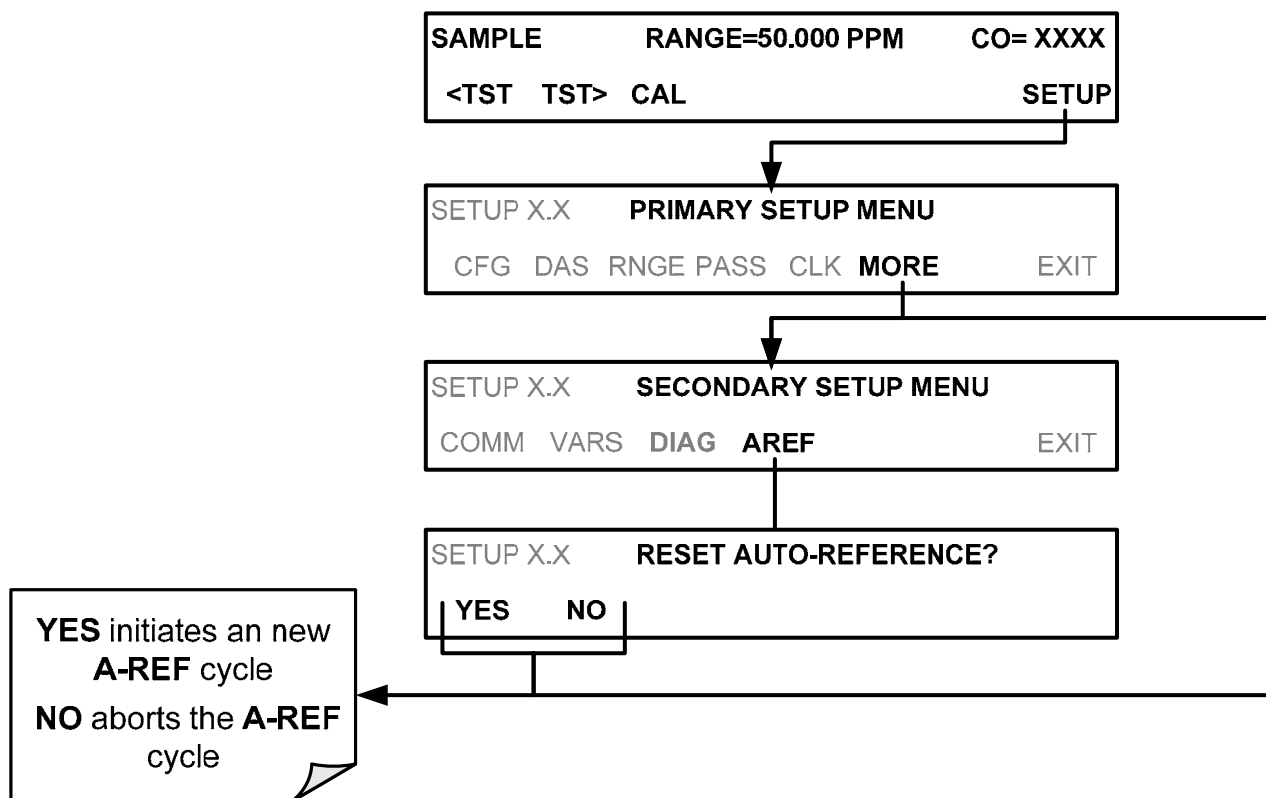

6.5. SETUP → MORE → VARS: INTERNAL VARIABLES (VARS)

The information found in Section 6.12 of the M300E/EM Operators Manual (P/N 04288) is applicable to the M300EU with the following exception(s):

- There is no **STABIL_GAS** variable available under the **VARS** menu of the M300EU.
- The following table supersedes Table 6-14 of the M300E/EM Operators Manual (P/N 04288).

Table 6-3: Test Functions Defined

NO.	VARIABLE	DESCRIPTION	ALLOWED VALUES
0	DAS_HOLD_OFF	Changes the internal data acquisition system (iDAS) hold-off time, which is the duration when data are not stored in the iDAS because the software considers the data to be questionable. That is the case during warm-up or just after the instrument returns from one of its calibration modes to SAMPLE mode. DAS_HOLD_OFF can be disabled entirely in each iDAS channel.	Can be between 0.5 and 20 minutes Default=15 min.
1	CONC_PRECISION	Allows the user to set the number of significant digits to the right of the decimal point display of concentration and stability values.	AUTO, 1, 2, 3, 4 Default=AUTO
2	DYN_ZERO	Dynamic zero automatically adjusts offset and slope of the CO response when performing a zero point calibration during an AutoCal (Chapter 7).	ON/OFF
3	DYN_SPAN	Dynamic span automatically adjusts slope and slope of the CO response when performing a zero point calibration during an AutoCal (Chapter 7). Note that the DYN_ZERO and DYN_SPAN features are not allowed for applications requiring EPA equivalency.	ON/OFF
4	CLOCK_ADJ	Adjusts the speed of the analyzer's clock. Choose the + sign if the clock is too slow, choose the - sign if the clock is too fast.	-60 to +60 s/day

6.6. SETUP → MORE → DIAG: USING THE DIAGNOSTICS FUNCTIONS

The information found in Section 6.13 of the M300E/EM Operators Manual (P/N 04288) is applicable to the M300EU with the following exception(s):

- There is no **DISPLAY SEQUENCE CONFIGURATION** submenu available under the **DIAG** menu of the M300EU.
- The following table supersedes Table 6-15 of the M300E/EM Operators Manual (P/N 04288).

Table 6-4: M300EU Diagnostic (DIAG) Submenus

DIAGNOSTIC FUNCTION AND MEANING	Front Panel Mode Indicator	
SIGNAL I/O: Allows observation of all digital and analog signals in the instrument. Allows certain digital signals such as valves and heaters to be toggled ON and OFF .	DIAG I/O	See M300E/EM Manual
ANALOG OUTPUT: When entered, the analyzer performs an analog output step test. This can be used to calibrate a chart recorder or to test the analog output accuracy.	DIAG AOUT	See M300E/EM Manual
ANALOG I/O CONFIGURATION: This submenu allows the user to configure the analyzer's four analog output channels, including choosing what parameter will be output on each channel. Instructions that appear here allow adjustment and calibration the voltage signals associated with each output as well as calibration of the analog to digital converter circuitry on the motherboard.	DIAG AIO	6.7.1
ELECTRIC TEST: The analyzer is performing an electric test. This test simulates IR detector signal in a known manner so that the proper functioning of the sync/demod board can be verified.	DIAG OPTIC	See M300E/EM Manual
DARK CALIBRATION: The analyzer is performing a dark calibration procedure. This procedure measures and stores the inherent dc offset of the sync/demod board electronics.	DIAG ELEC	See M300E/EM Manual
PRESSURE CALIBRATION: The analyzer records the current output of the sample gas pressure sensor. This value is used by the CPU to compensate the CO concentration.	DIAG PCAL	See M300E/EM Manual
FLOW CALIBRATION: This function is used to calibrate the gas flow output signals of sample gas and ozone supply. These settings are retained when exiting DIAG .	DIAG FCAL	See M300E/EM Manual

6.7. ANALOG OUTPUT CONFIGURATION

6.7.1. ANALOG I/O CONFIGURATION

Because the manner in which the analog outputs are implemented differs between the M300E/EM and the M300EU, there are significant differences in the manner in which the ANALOG I/O are manipulated.

THE ANALOG I/O CONFIGURATION SUBMENU

This section replaces Section 6.13.5.1 of the M300E/EM Operators Manual (P/N 04288).

Table 6-5: DIAG - Analog I/O Functions

SUB MENU	FUNCTION
AOUT CALIBRATED	Initiates a calibration of the A1 , A2 and A4 analog output channels that determines the slope and offset inherent in the circuitry of each output. These values are stored in the and applied to the output signals by the CPU automatically
CONC_OUT_1¹	Sets the basic electronic configuration of the A1 output. There are four options: <ul style="list-style-type: none"> • RANGE: Selects the signal type (voltage or current loop) and level of the output • A1 OFS: Allows them input of a DC offset to let the user manually adjust the output level • AUTO CAL: Enables / Disables the AOUT CALIBRATION Feature • CALIBRATED: Performs the same calibration as AOUT CALIBRATED, but on this one channel only.
CONC_OUT_2¹	Sets the basic electronic configuration of the A2 output. There are three options: <ul style="list-style-type: none"> • RANGE: Selects the signal type (voltage or current loop) and level of the output • A2 OFS: Allows them input of a DC offset to let the user manually adjust the output level • AUTO CAL: Enables / Disables the AOUT CALIBRATION Feature • CALIBRATED: Performs the same calibration as AOUT CALIBRATED, but on this one channel only.
TEST OUTPUT¹	Sets the basic electronic configuration of the A4 output. There are three options: <ul style="list-style-type: none"> • RANGE: Selects the signal type (voltage or current loop) and level of the output • A4 OFS: Allows them input of a DC offset to let the user manually adjust the output level • AUTO CAL: Enables / Disables the AOUT CALIBRATION Feature • CALIBRATED: Performs the same calibration as AOUT CALIBRATED, but on this one channel only.
AIN CALIBRATED	Initiates a calibration of the A-to-D Converter circuit located on the Mother Board.
¹ Changes to RANGE or REC_OFS require recalibration of this output.	

To configure the analyzer's three analog outputs, set the electronic signal type of each channel and calibrate the outputs. This consists of:

1. Selecting an output type (voltage or current, if an optional current output driver has been installed) and the signal level that matches the input requirements of the recording device attached to the channel.
2. Determine if the over-range feature is needed and turn it on or off accordingly.
3. If a Voltage scale is in use, a bipolar recorder offset may be added to the signal if required.
4. Choose a Test Channel parameter to be output on the channel.
5. Calibrating the output channel. This can be done automatically or manually for each channel.

To access the analog I/O configuration sub menu, press:

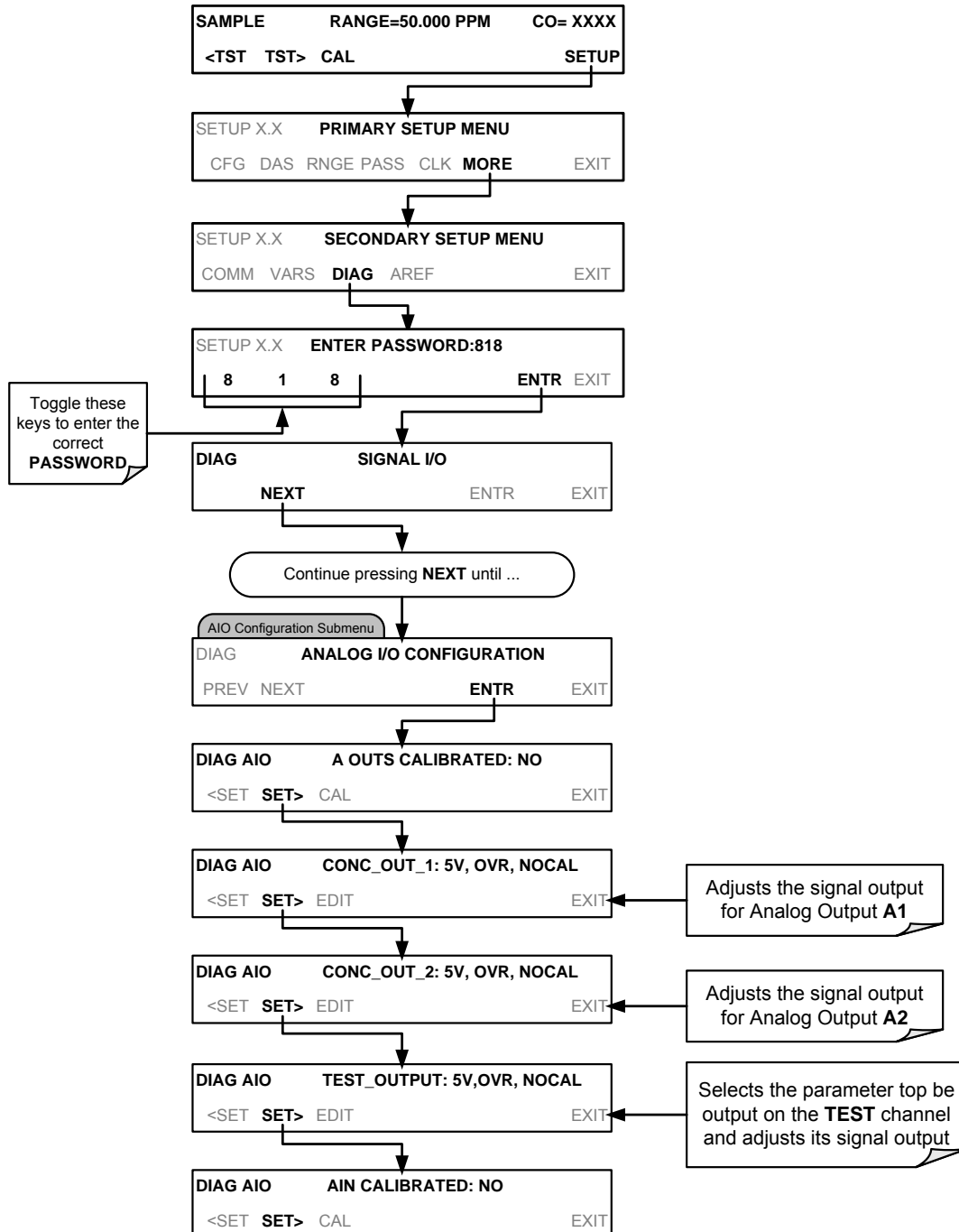

ANALOG OUTPUT SIGNAL TYPE AND RANGE SELECTION

The information found in Section 6.13.5.2 of the M300E/EM Operators Manual (P/N 04288) is applicable to the M300EU with the following exception(s):

- There are minor differences in the displays (e.g. **CONC_OUT_2** instead of **DATA_OUT_2**) User Notes:

TURNING THE ANALOG OUTPUT OVER-RANGE FEATURE ON/OFF

The information found in Section 6.13.5.3 of the M300E/EM Operators Manual (P/N 04288) is applicable to the M300EU with the following exception(s):

- There are minor differences in the displays (e.g. **CONC_OUT_2** instead of **DATA_OUT_2**) User Notes:

ADDING A RECORDER OFFSET TO AN ANALOG OUTPUT

The information found in Section 6.13.5.4 of the M300E/EM Operators Manual (P/N 04288) is applicable to the M300EU with the following exception(s):

- There are minor differences in the displays (e.g. **CONC_OUT_2** instead of **DATA_OUT_2**) User Notes:

NOT APPLICABLE SECTIONS

The following sections of the M300E/EM Operators Manual (P/N 04288) relating to configuration of the analog outputs **DO NOT** apply to the M300EU.

- **6.13.5.6 REPORTING GAS CONCENTRATIONS VIA THE M300E/EM ANALOG OUTPUT CHANNELS**
- **6.13.5.7 SETTING THE REPORTING RANGE SCALE FOR AN ANALOG OUTPUT**
- **6.13.5.8 SETTING DATA UPDATE RATE FOR AN ANALOG OUTPUT**
- **6.13.5.9 TURNING AN ANALOG OUTPUT ON OR OFF**

6.7.2. CALIBRATION OF THE ANALOG OUTPUTS

This section replaces Section 6.13.6 of the M300E/EM Operators Manual (P/N 04288).

ANALOG OUPUT calibration needs to be carried out on first startup of the analyzer (performed in the factory as part of the configuration process) or whenever re-calibration is required. The analog outputs can be calibrated automatically or adjusted manually.

During automatic calibration, the analyzer tells the output circuitry to generate a zero mV signal and high-scale point signal (usually about 90% of chosen analog signal scale) then measures actual signal of the output. Any error at zero or high-scale is corrected with a slope and offset.

Automatic calibration can be performed via the AOUTS CALIBRATION command, or by using the CAL button located inside each of the output submenus (e.g. **CONC_OUT_1**, **CONC_OUT_2** or **TEST_OUTPUT**). By default, the analyzer is configured so that calibration of analog outputs can be initiated as a group with the **AOUT CALIBRATION** command or individually.

ENABLING OR DISABLING THE AUTO-CAL FOR AN INDIVIDUAL ANALOG OUTPUT

The information found in Section 6.13.5.9 of the M300E/EM Operators Manual (P/N 04288) is applicable to the M300EU with the following exception(s):

- There are minor differences in the displays (e.g. **CONC_OUT_2** instead of **DATA_OUT_2**)

AUTOMATIC ANALOG OUTPUT CALIBRATION

The information found in Section 6.13.6.2 of the M300E/EM Operators Manual (P/N 04288) is applicable to the M300EU.

MANUAL CALIBRATION OF ANALOG OUTPUT CONFIGURED FOR VOLTAGE RANGES

The information found in Section 6.13.6.3 of the M300E/EM Operators Manual (P/N 04288) is applicable to the M300EU with the following exception(s):

- There are minor differences in the displays (e.g. **CONC_OUT_2** instead of **DATA_OUT_2**) User Notes:

MANUAL CALIBRATION OF ANALOG OUTPUTS CONFIGURED FOR CURRENT LOOP RANGES

The information found in Section 6.13.6.4 of the M300E/EM Operators Manual (P/N 04288) is applicable to the M300EU with the following exception(s):

- There are minor differences in the displays (e.g. **CONC_OUT_2** instead of **DATA_OUT_2**)
- The current output option can only be installed on outputs **A1** and **A2** of the M300EU

CALIBRATING THE INTERNAL A TO D CONVERTER (AIN CALIBRATION)

The information found in Section 6.13.6.5 of the M300E/EM Operators Manual (P/N 04288) is applicable to the M300EU.

6.7.3. SELECTING A TEST CHANNEL FUNCTION FOR OUTPUT A4

This section replaces Section 6.13.5.5 of the M300E/EM Operators Manual (P/N 04288)

The Test Functions available to be reported on analog output **A4** are:

Table 6-6: Test Channels Functions Available on the M300EU's Analog Output

TEST CHANNEL	DESCRIPTION	ZERO	FULL SCALE
NONE	TEST CHANNEL IS TURNED OFF		
CO MEAS	The raw output of the optical bench's IR detector during the measure phase of the m/r cycle	0 mV	5000 mV*
CO REF	The raw output of the optical bench's IR detector during the reference phase of the m/r cycle	0 mV	5000 mV*
SAMPLE PRESSURE	The pressure of gas in the optical bench's sample chamber	0 "Hg	40 "Hg-In-A
SAMPLE FLOW	The gas flow rate through the optical bench's sample chamber	0 cm ³ /min	6000 cm ³ /min
SAMPLE TEMP	The temperature of gas in the optical bench's sample chamber	0 C°	70 C°
BENCH TEMP	The temperature of optical bench's itself	0 C°	70 C°
WHEEL TEMP	The temperature of GFC wheel	0 C°	70 C°
OVEN TEMP	The temperature of the circulating air inside the convection oven section of the M300EU's interior.	0 C°	70 C°
PHT DRIVE	The drive voltage being supplied to the thermoelectric coolers of the IR photo-detector by the sync/demod Board.	0 mV	5000 mV
TEMP4	SPARE		

Once a function is selected, the instrument not only begins to output a signal on the analog output, but also adds **TEST** to the list of Test Functions viewable via the Front Panel Display.

To activate the **TEST** Channel and select a function, press:

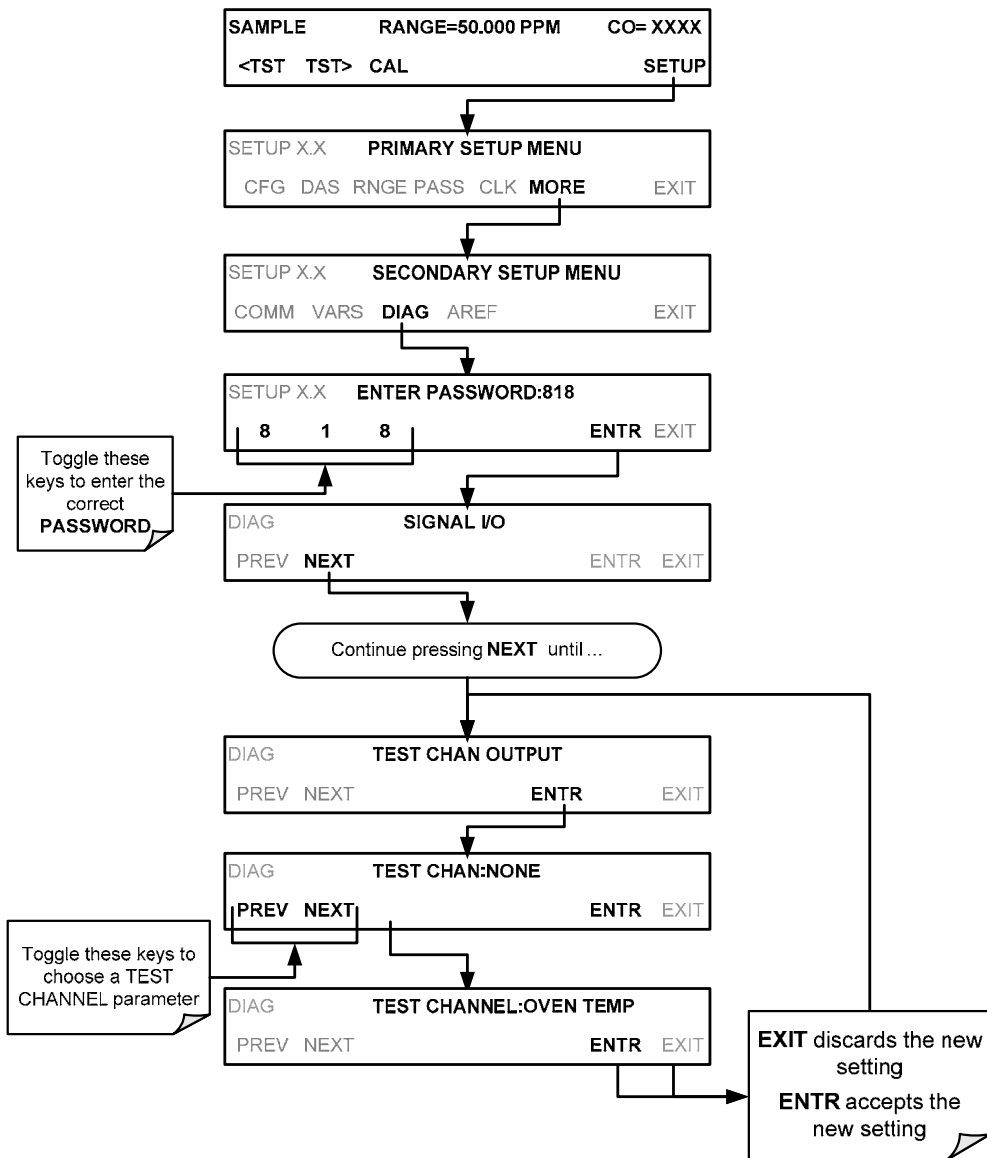

6.7.4. HESSEN PROTOCOL

The information found in Section 6.15.3 of the M300E/EM Operators Manual (P/N 04288) is applicable to the M300EU with the following exception(s):

- There is only one default gas type programmed into the M300EU. The following table replaces Table 6-32 of the M300E/EM Operators Manual (P/N 04288).

Table 6-7: M300EU Hessen GAS ID List

GAS DEFAULT	HESSEN GAS ID
CO	310

- The list of Hessen status flags for the M300EU is different from that of the M300E/EM. The following table replaces Table 6-33 of the M300E/EM Operators Manual (P/N 04288).

Table 6-8: Default Hessen Status Bit Assignments

STATUS FLAG NAME	DEFAULT BIT ASSIGNMENT
WARNING FLAGS	
SAMPLE FLOW WARNING	0001
BENCH TEMP WARNING	0002
SOURCE WARNING	0004
BOX TEMP WARNING	0008
WHEEL TEMP WARNING	0010
SAMPLE TEMP WARNING	0020
SAMPLE PRESSURE WARNING	0040
INVALID CONC (The Instrument's Front Panel Display Will Show The Concentration As "XXXX")	0080
OPERATIONAL FLAGS	
In Manual Calibration Mode	0200
In Zero Calibration Mode	0400
In Span Calibration Mode	0800
UNITS OF MEASURE FLAGS	
UGM	0000
MGM	2000
PPB	4000
PPM	6000
SPARE/UNUSED BITS	100, 1000, 8000
UNASSIGNED FLAGS (0000)	
AZERO WARN	RELAY BOARD WARNING
OVEN TEMP WARNING	FRONT PANEL WARNING
MP CAL	ANALOG CAL WARNING
PHOTO TEMP WARNING	CANNOT DYN ZERO
SYSTEM RESET	CANNOT DYN SPAN
REAR BOARD NOT DETECTED	INVALID CONC

USER NOTES:

7. CALIBRATION PROCEDURES

Calibration of the M300EU should be performed according to the procedures described in Chapters 7 & 8 of the M300E/EM Manual - P/N 04288 with the following notes and exceptions:

- Delivering span and zero gases for the higher resolution the M300EU can be difficult. Attention must be paid to the quality of the gasses, the level of contaminants in the gases as well as the history and conditioning of the gas delivery components.
- The analyzer must be continually operating with an adequate flow of sample gas, for 2 hours prior to performing a calibration (12 hours is recommended for the initial calibration).
 - DO NOT calibrate the analyzer if it has been turned off or if no sample gas has been flow through it within the last 2 hours.
- After this stabilization period is complete and just prior to performing the initial calibration, force the instrument to perform an auto-reference measurement by following the instructions in Section 6.4.2 .

REQUIRED EQUIPMENT, SUPPLIES AND EXPENDABLES

- Gas lines to and from the analyzer should be PTFE or FEP Teflon, glass, stainless steel or brass only.
- Zero-air source (defined in Section 7.1.2 of the M300E/EM Operators Manual).
 - Zero air must include at least 5% O₂ (required for the proper operation of the CO scrubber).
 - If a zero air generator, such as the Teledyne Instruments M701, is used it **MUST** be equipped with a hydrocarbon (HC) & CO scrubber option. For the Teledyne Instruments M701, this is Option 2B.
- Span gas source (defined in Section 7.1.3 of the M300E/EM Operators Manual).
- A recording device such as a strip-chart recorder and/or data logger (optional). Data recording device should be capable of bi-polar operation so that negative readings can be recorded.
- For electronic documentation, the internal data acquisition system can be used.

NOTE

If any problems occur while performing the following calibration procedures, refer to Chapter 11 of this manual for troubleshooting tips.

MANUAL CALIBRATION

The information found in Section 7.2 of the M300E/EM Operators Manual (P/N 04288) is applicable to the M300EU with the following exception(s).

- **STEP3 – ZERO/SPAN CALIBRATION**
 - Set the display to show the **STABILITY** test function (same as the **CO STB** function mentioned in the M300E/EM operator's manual).
 - There is no **GAS TO CAL** step because the M300EU cannot be modified to include the O₂ and CO₂ sensor packages.

MANUAL CALIBRATION CHECKS

The information found in Section 7.3 of the M300E/EM Operators Manual (P/N 04288) is applicable to the M300EU with the following exception(s).

- Set the display to show the **STABILITY** test function.

MANUAL CALIBRATION WITH ZERO/SPAN VALVES

The information found in Section 7.4 of the M300E/EM Operators Manual (P/N 04288) is applicable to the M300EU with the following exception(s).

- Set the display to show the **STABILITY** test function.
- There is no **GAS TO CAL** step.

MANUAL CALIBRATION CHECKS WITH ZERO/SPAN VALVES

The information found in Section 7.5 of the M300E/EM Operators Manual (P/N 04288) is applicable to the M300EU with the following exception(s).

- Set the display to show the **STABILITY** test function.
- There is no **GAS TO CAL** step.

CALIBRATION WITH REMOTE CONTACT CLOSURES

The information found in Section 7.6 of the M300E/EM Operators Manual (P/N 04288) is applicable to the M300EU with the following exception(s).

NOTE

It is required that the analyzer be forced to perform an auto-reference measurement just prior to calibration, however this cannot be forced via the analyzer’s digital control inputs.

The A-REF measurement can only be initiated using either the instrument’s front pane interface or via Teledyne Instruments’ APICOM emulator software.

AUTOMATIC ZERO/SPAN CAL/CHECK (AUTOCAL)

The information found in Section 7.7 of the M300E/EM Operators Manual (P/N 04288) is applicable to the M300EU with the following exception(s).

- The following table replaces Table 7-2 of the M300E/EM Operators Manual (P/N 04288).

Table 7-1: AUTOCAL Modes

MODE NAME	ACTION
DISABLED	Disables the Sequence
ZERO	Causes the Sequence to perform a zero calibration/check
ZERO-SPAN	Causes the Sequence to perform a zero and span concentration calibration/check
SPAN	Causes the Sequence to perform a span concentration calibration/check
AUTO-REF	Causes the analyzer to perform an auto-reference measurement.

CO CALIBRATION QUALITY

The information found in Section 7.8 of the M300E/EM Operators Manual (P/N 04288) is applicable to the M300EU.

CALIBRATION OF OPTIONAL SENSORS

The following Sections do not apply to the M300EU:

- **7.9.1 SECTION O₂ SENSOR CALIBRATION PROCEDURE**
- **7.9.2 CO₂ SENSOR CALIBRATION PROCEDURE**

8. EPA PROTOCOL CALIBRATION

The information found in Chapter 8 of the M300E/EM Operators Manual (P/N 04288) is applicable to the M300EU.

USER NOTES:

USER NOTES:

9. INSTRUMENT MAINTENANCE

The information found in Chapter 9 of the M300E/EM Operators Manual (P/N 04288) is applicable to the M300EU with the following exception(s):

- The oven temperature should be tracked along with the other parameters listed on Table 9-2 of the M300E/EM Operators Manual (see Table 9-1 below).

9.1. PERFORMING AN AUTO-REFERENCE MEASUREMENT AFTER MAINTENANCE

It is very important to manually initiate an **A-REF** measurement whenever any maintenance is performed on the M300EU, particularly if that maintenance involves:

- Opening the top cover or the front panel while the instrument is making **A-REF** measurements.
- Opening the top cover or the front panel at any time when the next ACAL scheduled **A-REF** measurement cycle is < 2 hours away.
- Turning off the analyzer at any time when the next ACAL scheduled **A-REF** measurement cycle is < 2 hours away.

This should be done no sooner than 2 hours after the M300EU has been operating with the front panel / top cover properly closed and sealed. Once this manual A-REF measurement is performed; the analyzer will discard any erroneous A-REF ratios that may have been recorded before the instrument's oven temperature had a chance to re-stabilize.

USER NOTES:

USER NOTES:

Table 9-1: M300EU Test Function Record

FUNCTION	OPERATING MODE*	DATE RECORDED											
STABILITY	ZERO CAL												
CO MEAS	ZERO CAL												
MR RATIO	ZERO CAL												
	SPAN CAL												
PRES	SAMPLE												
PHT DRIVE	SAMPLE AFTER WARM-UP												
SLOPE	SPAN CAL												
OFFSET	ZERO CAL												
OVEN TEMP	SAMPLE												

USER NOTES:

10. THEORY OF OPERATION

10.1. MEASUREMENT METHOD

The information found in Section 10.1 of the M300E/EM Operators Manual (P/N 04288) is applicable to the M300EU with the following addition. It is recommended that you read that section before continuing.

10.1.1. AUTO-REFERENCE RATIO

The higher resolution of the M300EU makes it more susceptible than the M300E/EM to the effects of a variety of environmental conditions such as:

- Drift related to the age of the optical bench components (e.g. the IR lamp, the IR detector, etc.)
- Variations in the temperature of the sample gas (affecting its density).
- Interferents, specifically CO₂ and H₂O.

The M300EU accounts for these issues by adding an additional component to the CO concentration calculation call the Auto-reference ratio.

This ratio is arrived at in the same manner as the measure/reference ratio (described in Section 10.1.3.2 of the M300E/EM Operators Manual) with the difference that that during the measurements that are to calculate the **A-REF** ratio, the gas stream is switched to pass through a scrubber that completely removes all CO from the sample gas. Therefore the measured difference between **CO MEAS** and **CO REF** represents the exact state of the sample gas and the optical bench's sensors without CO present.

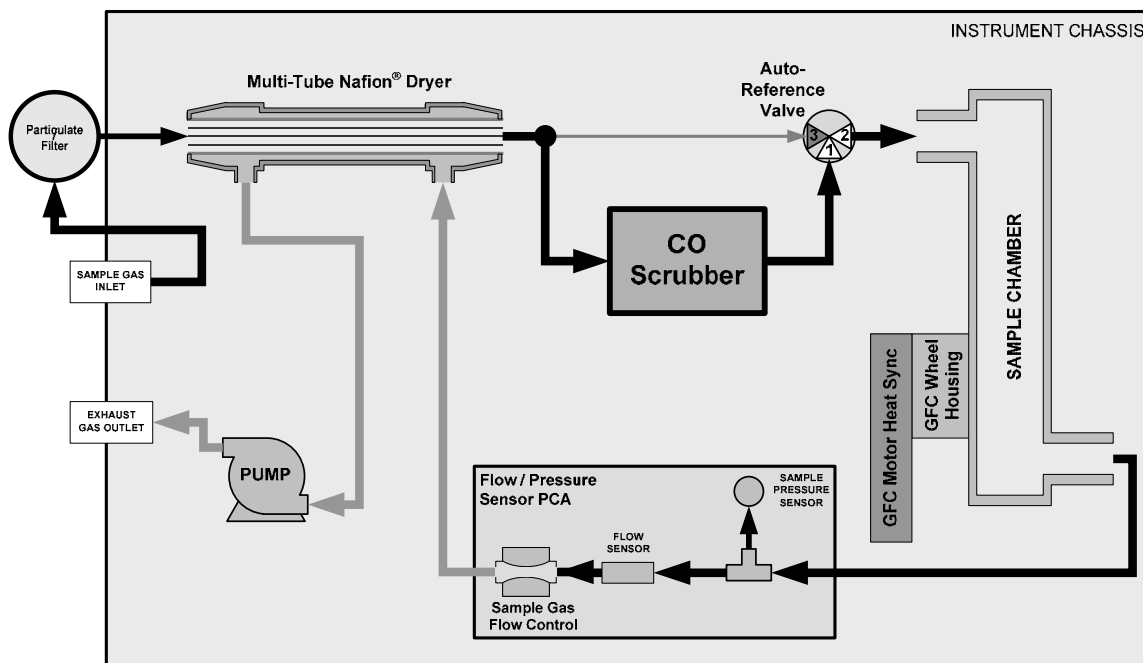

Figure 10-1: M300EU Gas flow during Auto-Reference Measurements

The analyzer averages the last five **A-REF** ratios and multiplies this average by a constant and the result is included in the final CO calculation as a positive or negative offset.

Whenever an **A-REF** is manually initiated either by using the **AREF** submenu via the front panel (see Section 6.4.2) or by activating pin-7 of the instrument's digital control input connector, all previously stored A-REF ratios are erased and the new ratio inserted. This allows the user to correct for a bad A-REF reading (e.g. the oven temperature during the A-REF cycle was too high/low)

The auto-reference measurement takes approximately 15 minutes. To ensure that the sample chamber of the optical bench is properly purged when switching between the sample and auto-reference measurements and vice-versa, each auto-reference cycle includes a 3 minute dwell period before and after the actual measurements are made. This cycle is restarted every 4 hours by an ACAL sequence, programmed at the factory (see Section 6.4).

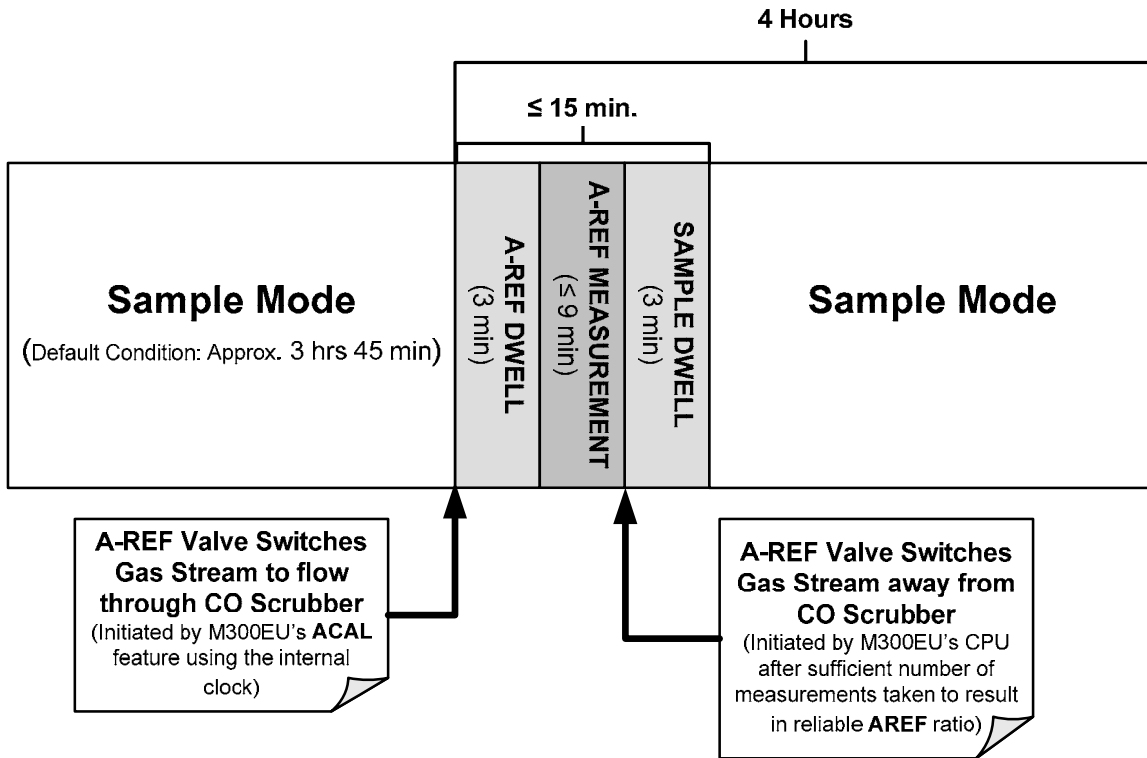

Figure 10-2: Auto-Reference Measurement Cycle

10.2. PNEUMATIC OPERATION

With the exceptions to the difference discussed on other portions of this addendum regarding the A-REF CO scrubber and the Nafion® dryer, (See Sections 3.2, 5.1.1, 5.1.2, 5.1.3, 10.1.1 & 0) the pneumatic operation is the same as that described in Section 10.3 of the M300E/EM Operators Manual (P/N 04288).

10.2.1. THE A-REF CARBON MONOXIDE SCRUBBER

A special CO scrubber is used to remove all of the CO from the gas stream when the instrument is performing an auto-reference measurement. The scrubber contains a substance that catalyses a chemical reaction converting any CO in the gas stream to CO₂.

NOTE

To operate properly, the gas flowing through the scrubber must contain at least 5% O₂.
This includes calibration gases such as zero air and span gas.

The O₃ scrubber is located inside the auto-reference valve assembly.

10.2.2. THE A-REF VALVE ASSEMBLY

The auto-reference valve assembly is located next to the optical bench, at the rear of the analyzer between the Nafion® dryer and the outer wall of the instrument (see Figure 3-1). The following table describes the state of each valve during the analyzer's various operational modes (see Figure 10-1).

Table 10-1: Auto-Reference Valve Operating States

Mode	Valve State	VALVE PORT CONNECTIONS
SAMPLE (Normal State)	Gas stream from Nafion® Dryer & SAMPLE inlet	3 → 2
A-REF DWELL	Gas stream from CO scrubber	1 → 2
A-REF MEASUREMENT	Gas stream from CO scrubber	1 → 2
SAMPLE DWELL	Gas stream from Nafion® Dryer & SAMPLE inlet	3 → 2

10.2.3. THE NAFION® DRYER.

Normal room air contains a certain amount of water vapor. While H₂O is a very low-level interferent for IR absorption (in the same range as CO) it can cause enough interference to affect the high-resolution measurements of the M300EU.

To account for this the M300EU has a special dryer added to the gas stream. The dryer consists of a bundle of parallel tubes of Nafion®, a co-polymer similar to Teflon® that absorbs water very well but not other chemicals. The multiple tube design of this dryer creates a large reactive surface without causing a restriction in the higher gas flow rate required by the M300EU that a long single tube style dryer would.

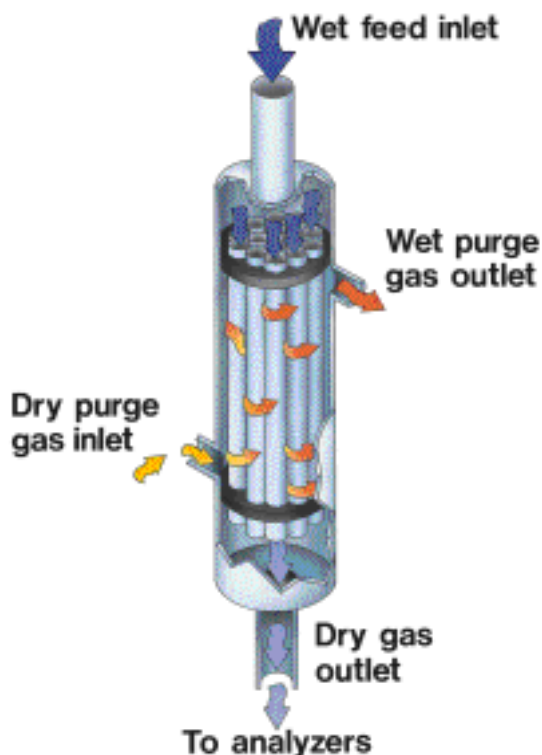

Figure 10-3: Semi-Permeable Membrane Drying Process

The dryer consists of a bundle of 0.030" O.D. Nafion® tubes housed within a single large tube shell. Sample gas flows within the Nafion tubes while water vapor absorbs into the tubular membrane walls and is removed. Moisture permeating the tubing is carried away by a dry purge gas within the shell that flows countercurrent to the sample gas.

This process is called per-evaporation and is driven by the humidity gradient between the inner and outer tubes as well as the flow rates and pressure difference between inner and outer tubing. Unlike micro-porous membrane permeation, which transfers water through a relatively slow diffusion process, per-evaporation is a simple kinetic reaction. Therefore, the drying process occurs quickly, typically within milliseconds.

The first step in this process is a chemical reaction between the molecules of the Nafion® material and water, other chemical components of the gases to be dried are usually unaffected. The chemical reaction is based on hydrogen bonds between the water molecule and the Nafion material. Other small polar gases that are capable of hydrogen bonds can be absorbed this way, too, such as ammonia (NH₃) and some low molecular amines. The gas of interest to the M300EU, CO, does not get absorbed and passes through the dryer unaltered.

To provide a dry purge gas for the outer side of the Nafion tube, the M300EU returns some of the dried air from the inner tube to the outer tube (see Figure 3-2).

When the analyzer is first started, or if the instrument is turned on after having been off for more than 30 minutes, the humidity gradient between the inner and outer tubes is not very large and the dryer's efficiency is low at first but improves as this cycle reduces the moisture in the sample gas and settles at a minimum humidity.

The dryer used in the M300EU is capable of adequately drying ambient air to a dew point of $\leq -6^{\circ}\text{C}$ (~4000 ppm residual H₂O) at the flow rate of the analyzer.

10.3. ELECTRONIC OPERATION

10.3.1. OVERVIEW

The information found in Section 10.4.1 of the M300E/EM Operators Manual (P/N 04288) is applicable to the M300EU with the following exception(s):

- This figure replaces Figure 10-9of the M300E/EM Operators Manual.

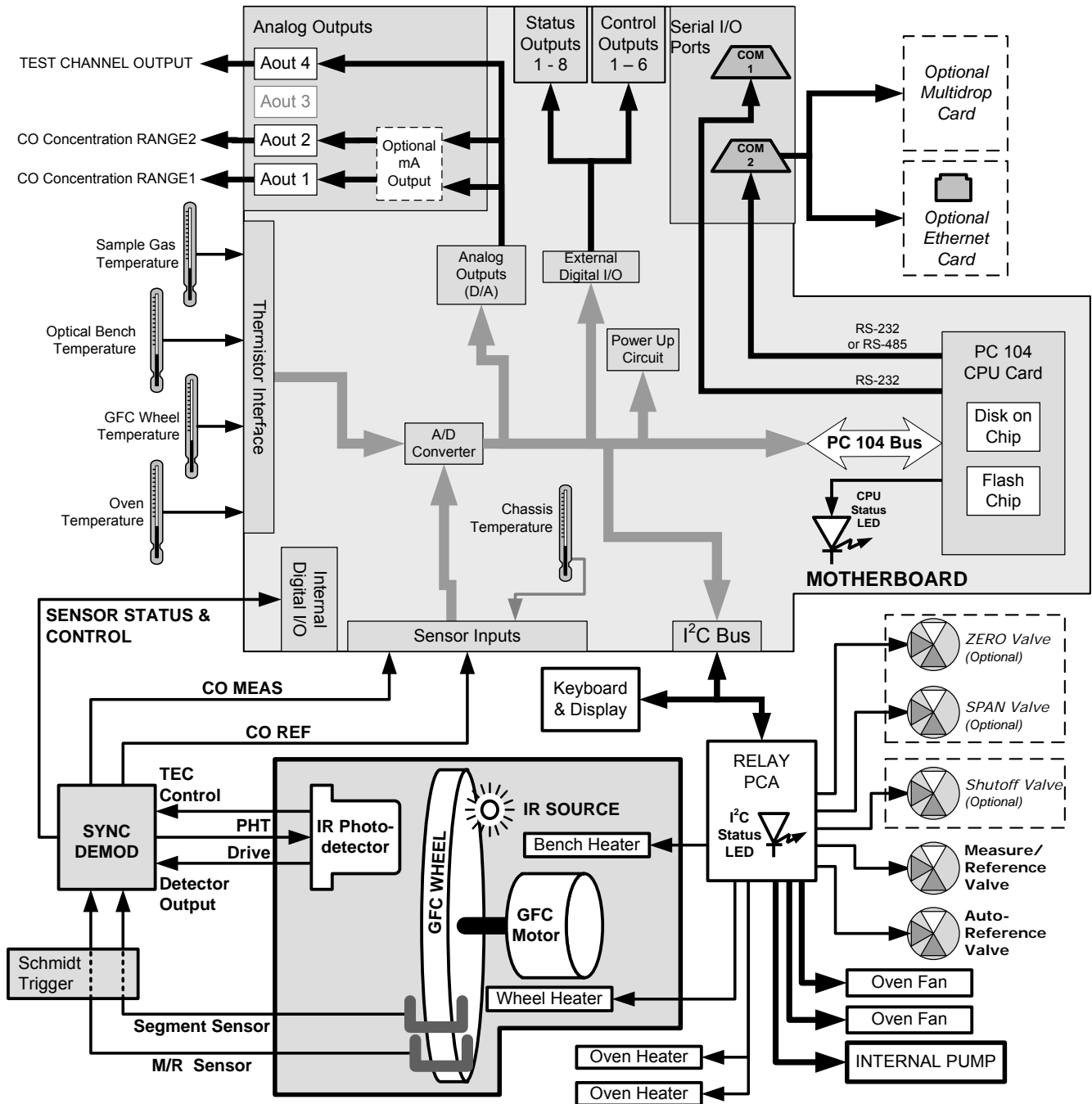

Figure 10-4: M300EU Electronic Overview Block Diagram

10.3.2. THE RELAY PCA

The information found in Section 10.4.5 of the M300E/EM Operators Manual (P/N 04288) is applicable to the M300EU with the following exception(s):

10.3.2.1. Temperature Control of the Convection Oven

The information found in Section 10.4.5.1 of the M300E/EM Operators Manual (P/N 04288) is applicable to the M300EU with the following exception(s):

- There are two heaters attached to either side of the optical bench (see Figure 3-1) that radiate heat into the insulated, oven area of the analyzer. Each heater has a fan attached to it that circulates the heated air throughout the oven airspace.
- The CPU senses the temperature level from different places inside the oven area and determines the overall temperature of the oven. Eventually, all of the components within the oven area will stabilize at the same temperature. This usually takes about 2 hours after the instrument is turned **ON**.
- A separate fan blows directly on the A-to-D conversion circuitry of the motherboard to more keep it at the same temperature as the oven airspace in order to eliminate any temperature-coefficient related offset.

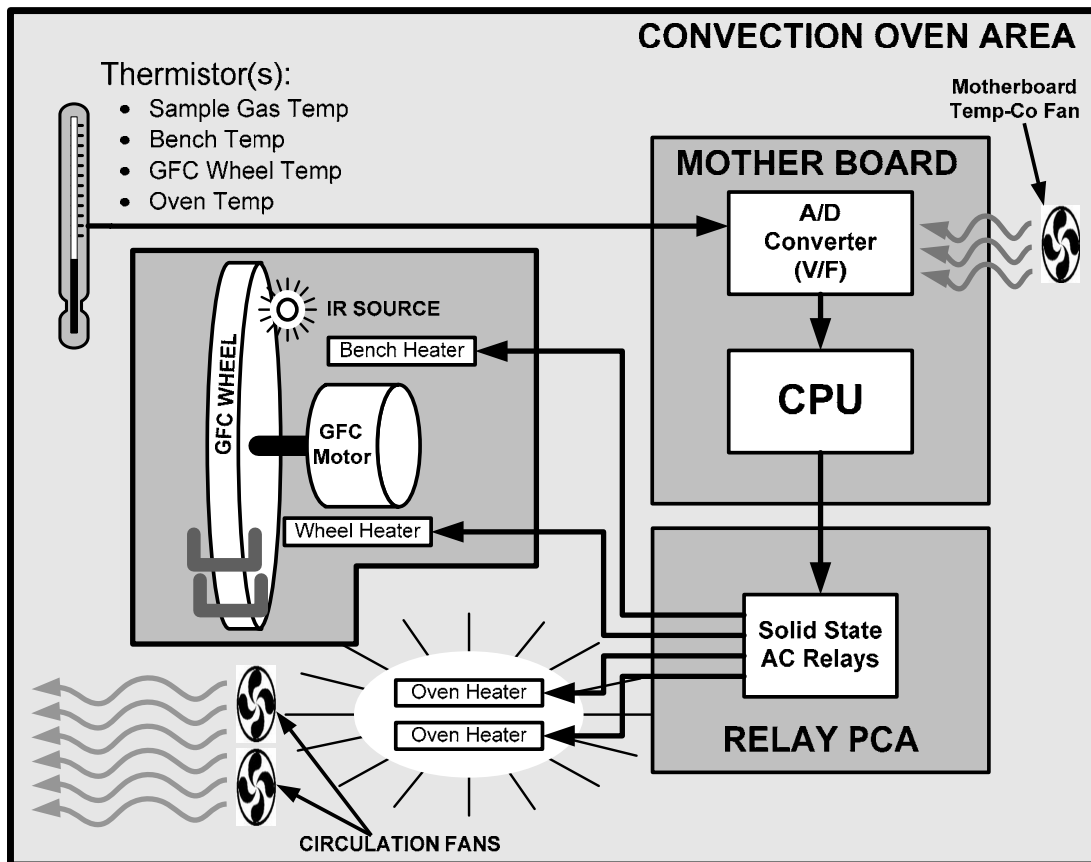

Figure 10-5: M300EU Heating Control Block Diagram

10.3.2.2. Oven Heaters AC Power Configuration

The two main heaters for the convection oven area of the M300EU are AC heaters. A jumper, located in line on the power connection between the relay PCA and the heaters, set the heaters in one of two configurations:

- In parallel for 115 VAC operation, or;
- In series for 230 VAC operation.

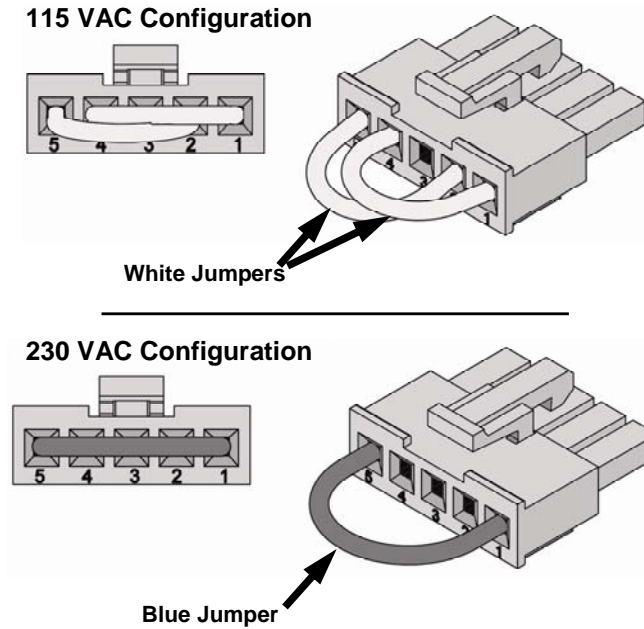

Figure 10-6: M300EU Oven Heater Configuration Jumpers

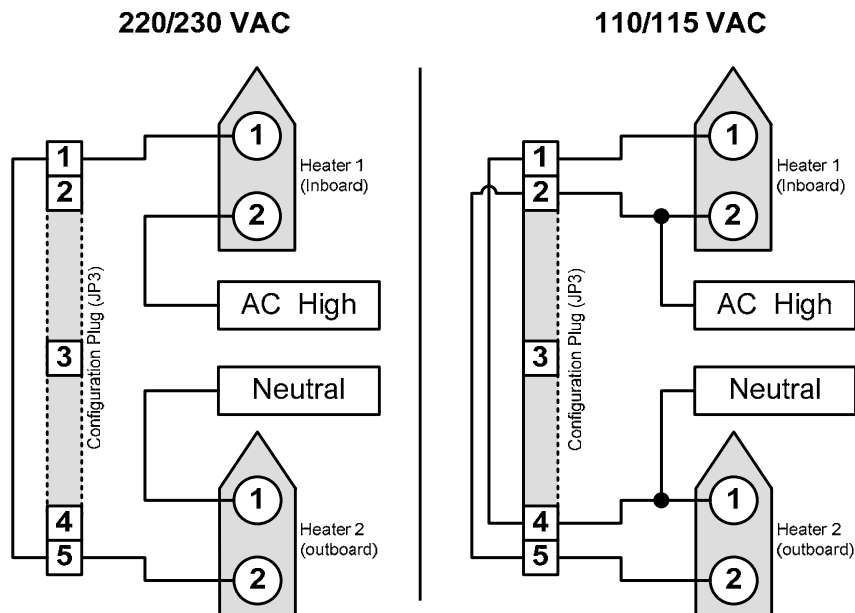

Figure 10-7: M300EU Oven Heater Configuration Circuit

10.3.2.3. Status LED's

This information replaces that found in Sections 10.4.5.5 of the M300E/EM Operators Manual.

- Eight LED's are located on the analyzer's relay board to show the current status on the various control functions performed by the relay board (see Figure 10-14 of the M300E/EM Operators Manual).
- They are:

Table 10-2: Relay Board Status LED's

LED	COLOR	FUNCTION	STATUS WHEN LIT	STATUS WHEN DARK
D1	RED	Watchdog Circuit	Cycles On/Off Every 3 Seconds under direct control of the analyzer's CPU.	
D2	YELLOW	Wheel Heater	HEATING	NOT HEATING
D3	YELLOW	Bench Heater	HEATING	NOT HEATING
D4	YELLOW	Oven Heaters	HEATING	NOT HEATING
D5	GREEN	Sample/Cal Gas Valve Option	Valve Open to CAL GAS FLOW	Valve Open to SAMPLE GAS FLOW
D6	GREEN	Zero/Span Gas Valve Option	Valve Open to SPAN GAS FLOW	Valve Open to ZERO GAS FLOW
D7	GREEN	Shutoff Valve Option	Valve Open to CAL GAS FLOW	Valve CLOSED to CAL GAS FLOW
D8	GREEN	IR SOURCE	Source ON	Source OFF

10.3.3. MOTHERBOARD

The information found in Section 10.4.6 of the M300E/EM Operators Manual (P/N 04288) is applicable to the M300EU with the following additions:

10.3.3.1. A to D Conversion

Because the M300EU has much higher resolution and sensitivity than the M300E/EM, the possibility that temperature-coefficient related drift could occur in the 10.3.3.1. A to D conversion circuitry if there were a significant difference in temperature between the converter and the surrounding airspace. To prevent this, a fan direct heated air directly onto the A to D converter area of the motherboard to ensure that it is as close as possible to the current temperature of the oven area.

10.3.3.2. Sensor Inputs

OVEN TEMPERATURE SENSOR

A thermistor is located in the center of the insulated oven area (see Figure 3-1). It measures the analyzer's inside temperature. This information is stored by the CPU and can be viewed by the user for troubleshooting purposes via the front panel display by selecting the test function **OVEN TEMP** or reported via the instruments **TEST CHANNEL** analog output (A4) by setting the output function also named **OVEN TEMP**.

10.3.4. POWER DISTRIBUTION

The information found in Section 10.4.5 of the M300E/EM Operators Manual (P/N 04288) is applicable to the M300EU with the following exception(s):

- This Figure replaces Figure 10-15 of the M300E/EM Operators Manual (P/N 04288).

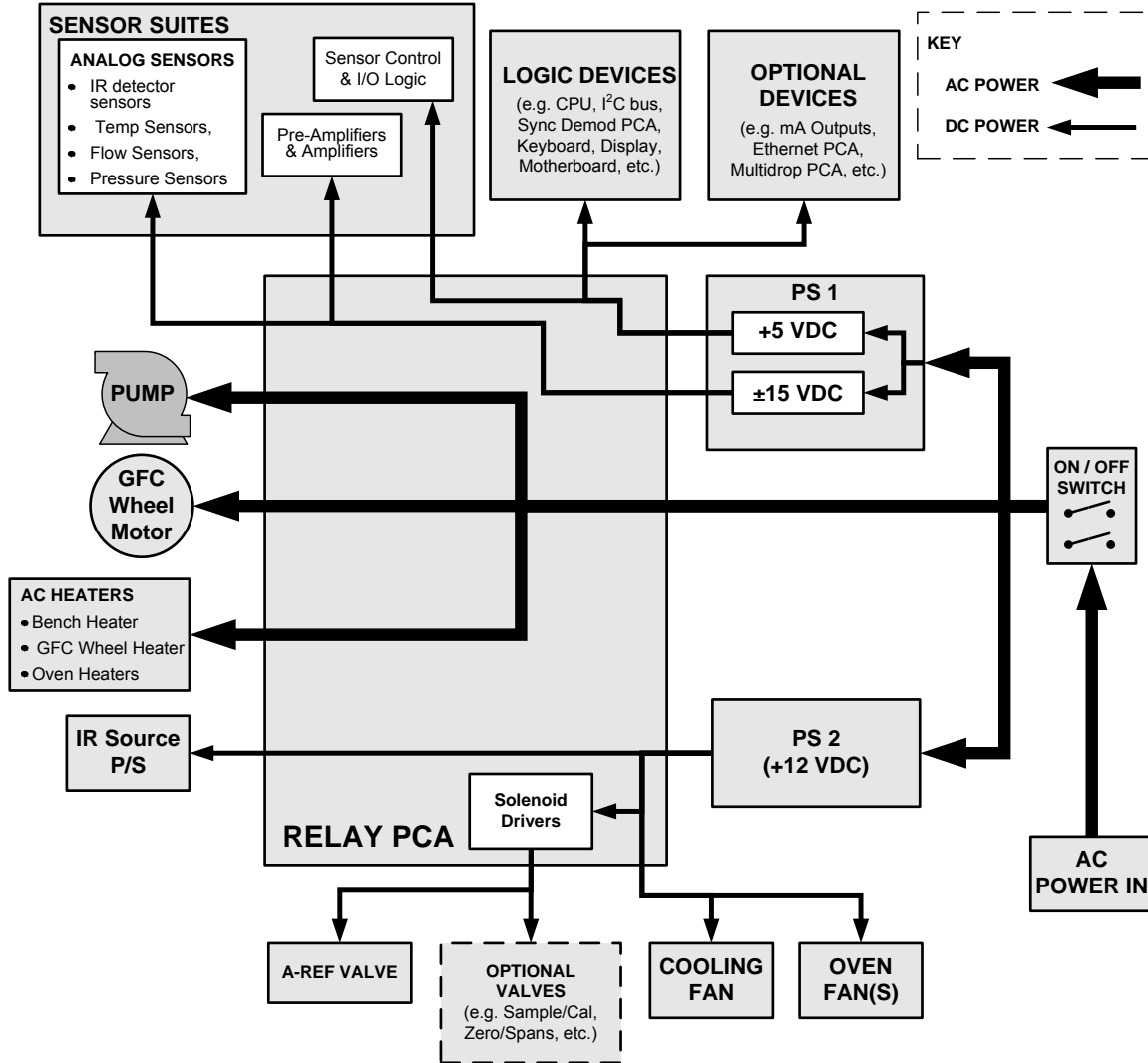



Figure 10-8: M300EU Distribution Block Diagram

USER NOTES:

11. TROUBLESHOOTING & REPAIR

11.1. GENERAL NOTES

	<p style="text-align: center;">CAUTION</p> <p>THE OPERATIONS OUTLINED IN THIS CHAPTER MUST BE PERFORMED BY QUALIFIED MAINTENANCE PERSONNEL ONLY.</p> <p>PLEASE READ CHAPTER 11 OF THE M300E/EM MANUAL (P/N 04288) BEFORE ATTEMPTING THE FOLLOWING TROUBLE SHOOTING OR REPAIR PROCEDURES</p>
---	--

	<p style="text-align: center;">CAUTION</p> <p>RISK OF ELECTRICAL SHOCK. SOME OPERATIONS NEED TO BE CARRIED OUT WITH THE ANALYZER OPEN AND RUNNING.</p> <p>EXERCISE CAUTION TO AVOID ELECTRICAL SHOCKS AND ELECTROSTATIC OR MECHANICAL DAMAGE TO THE ANALYZER.</p> <p>DO NOT DROP TOOLS INTO THE ANALYZER OR LEAVE THOSE AFTER YOUR PROCEDURES.</p> <p>DO NOT SHORTEN OR TOUCH ELECTRIC CONNECTIONS WITH METALLIC TOOLS WHILE OPERATING INSIDE THE ANALYZER.</p> <p>USE COMMON SENSE WHEN OPERATING INSIDE A RUNNING ANALYZER.</p>
---	--

The information found in Chapter 11 of the M300E/EM Operators Manual (P/N 04288) is applicable to the M300EU with the exceptions below.

	<p style="text-align: center;">CAUTION</p> <p>ALWAYS ALLOW THE M300EU TO OPERATE FOR AT LEAST TWO HOURS AFTER ALL REPAIRS HAVE BEEN FINISHED AND THE INSTRUMENTS CASE IS RE-CLOSED.</p> <p>AT THE END OF THIS 2-HOUR STABILIZATION PERIOD MANUALLY INITIATE AN A-REF MEASUREMENT (SEE SECTION 6.4.2)</p>
---	---

11.2. FAULT DIAGNOSIS WITH WARNING MESSAGES

The following Table replaces Table 11-1; of the M300E/EM Operators Manual.

Table 11-1: Warning Messages - Indicated Failures

WARNING MESSAGE	FAULT CONDITION	POSSIBLE CAUSES
BENCH TEMP WARNING	The optical bench temp is controlled at 48 ± 2 °C.	Bad bench heater Bad bench temperature sensor Bad relay controlling the bench heater Entire relay board is malfunctioning I ² C buss malfunction
BOX TEMP WARNING	Box Temp is < 5 °C or > 48 °C.	NOTE: For M300EU's operating for at least 2 hours, the box temperature typically should be the same as the oven temperature (46°C). Stopped motherboard stabilization fan Stopped oven heater fan (there are two) Failed oven heater (s) Failed oven fan(s) Failed oven temperature sensor Failed relay controlling the one of the oven heaters Failed relay board I ² C buss
CANNOT DYN SPAN	Dynamic Span operation failed	Measured concentration value is too high or low. Concentration slope value to high or too low
CANNOT DYN ZERO	Dynamic Zero operation failed	Measured concentration value is too high. Concentration offset value to high.
CONFIG INITIALIZED	Configuration and Calibration data reset to original Factory state.	Failed disk on chip User erased data
DATA INITIALIZED	Data Storage in iDAS was erased	Failed disk on chip User cleared data
FRONT PANEL WARN	The CPU is unable to Communicate with the Front Panel Display /Keyboard	Warning only appears on serial I/O com port(s) Front panel display will be frozen, blank or will not respond. Failed keyboard I ² C buss failure Loose connector/wiring
PHOTO TEMP WARNING	PHT DRIVE is >4800 mVDC	Failed IR photo-detector Failed sync/demod board IR photo-detector improperly attached to the sample chamber Bench temp too high.
OVEN TEMP WARNING	The temperature of the insulated convection oven area of the analyzer is outside of the specified limits.	Oven temperature outside of specified range Failed oven heater (s) Failed oven fan(s) Failed oven temperature sensor Relay controlling the one of the oven heater Failed relay board I ² C buss
REAR BOARD NOT DET	Mother Board not detected on power up.	Warning only appears on serial I/O com port(s) Front panel display will be frozen, blank or will not respond. Massive failure of mother board
RELAY BOARD WARN	The CPU cannot communicate with the Relay Board.	I ² C buss failure Failed relay board Loose connectors/wiring

(Table continued on next page)

Table 11-1: Warning Messages – Indicated Failures (cont.)

WARNING MESSAGE	FAULT CONDITION	POSSIBLE CAUSES
SAMPLE FLOW WARN	Sample flow rate is <1400 cm ³ /min or > 2200 cm ³ /min.	Failed sample pump Blocked sample inlet/gas line Dirty particulate filter Leak downstream of critical flow orifice Failed flow sensor/circuitry
SAMPLE PRES WARN	Sample Pressure is <10 in-Hg or > 35 in-Hg Normally 29.92 in-Hg at sea level decreasing at 1 in-Hg per 1000 ft of altitude (with no flow – pump disconnected).	If sample pressure is < 10 in-hg: <ul style="list-style-type: none"> o Blocked particulate filter o Blocked sample inlet/gas line o Failed pressure sensor/circuitry If sample pressure is > 35 in-hg: <ul style="list-style-type: none"> o Pressurized sample gas. Install vent o Blocked vent line on pressurized sample/zero/span gas supply o Bad pressure sensor/circuitry
SAMPLE TEMP WARN	Sample temperature is < 10°C or > 100°C.	Ambient temperature outside of specified range Failed bench heater Failed bench temperature sensor Relay controlling the bench heater Failed relay board I ² C buss
SOURCE WARNING	Occurs when CO Ref is <1250 mVDC or >4950 mVDC. Either of these conditions will result in an invalid M/R ratio.	GFC wheel stopped Failed sync/demod board If status LED's on the sync/demod board <u>ARE</u> flashing the cause is most likely a failed: IR source Relay board I ² C buss IR photo-detector
SYSTEM RESET	The computer has rebooted.	This message occurs at power on. If you have not cycled the power on your instrument: <ul style="list-style-type: none"> o Failed +5 VDC power, o Fatal error caused software to restart o Loose connector/wiring
WHEEL TEMP WARNING	The filter wheel temperature is controlled at 68 ± 2 °C	Blocked cooling vents below GFC Assembly. Make sure that adequate clear space beneath the analyzer. Analyzer's top cover removed Wheel heater Wheel temperature sensor Relay controlling the wheel heater Entire relay board I ² C buss

11.2.1. FAULT DIAGNOSIS WITH TEST FUNCTIONS

The following table supersedes Table 11.2 of the M300E/EM Operators Manual (P/N 04288).

Table 11-2: Test Functions - Indicated Failures

TEST FUNCTIONS (As Displayed)	INDICATED FAILURE(S)
TIME	Time of day clock is too fast or slow To adjust See Section 6.6 of the M300E/EM Operators Manual (P/N 04288). Battery in clock chip on CPU board may be dead.
RANGE	Incorrectly configured measurement range(s) could cause response problems with a Data logger or chart recorder attached to one of the analog output. If the Range selected is too small, the recording device will over range. If the Range is too big, the device will show minimal or no apparent change in readings.
STABIL	Indicates noise level of instrument or CO concentration of sample gas (See Section 11.4.2 of the M300E/EM Operators Manual for causes).
CO MEAS & CO REF	If the value displayed is too high the IR Source has become brighter. Adjust the variable gain potentiometer on the sync/demod board (See Section 11.6.3 of the M300E/EM Operators Manual) If the value displayed is too low or constantly changing and the CO REF is OK: <ul style="list-style-type: none"> o Failed multiplexer on the mother board o Failed sync/demod board o Loose connector or wiring on sync/demod board If the value displayed is too low or constantly changing and the CO REF is BAD : <ul style="list-style-type: none"> o GFC wheel stopped or rotation is too slow o Failed sync/demod board IR source o Failed IR source o Failed relay board o Failed I²C buss o Failed IR photo-detector
MR RATIO	When the analyzer is sampling zero air and the ratio is too low: <ul style="list-style-type: none"> o The reference cell of the GFC wheel is contaminated or leaking. o The alignment between the GFC wheel and the segment sensor, the M/R sensor or both is incorrect. o Failed sync/demod board When the analyzer is sampling zero air and the ratio is too high: <ul style="list-style-type: none"> o Zero air is contaminated o Failed IR photo-detector
PRES	See Table 11-1 for SAMPLE PRES WARN
SAMPLE FL	Check for gas flow problems. see Section 11.1.6 of the M300E/EM Operators Manual)
SAMPLE TEMP	SAMPLE TEMP should be close to BENCH TEMP. Temperatures outside of the specified range or oscillating temperatures are cause for concern
BENCH TEMP	Bench temp control improves instrument noise, stability and drift. Temperatures outside of the specified range or oscillating temperatures are cause for concern. See Table 11-1 for BENCH TEMP WARNING
WHEEL TEMP	Wheel temp control improves instrument noise, stability and drift. Outside of set point or oscillating temperatures are causes for concern. See Table 11-1 for WHEEL TEMP WARNING
BOX TEMP	If the box temperature is out of range: <ul style="list-style-type: none"> o Check the motherboard stabilization fan (see Figure 3-1). o See Table 11-1 for BOX TEMP WARNING.
OVEN TEMP	If the oven is temperature is out of range, check both of the oven heater fans in the power supply module. Areas to the side and rear of instrument should allow adequate ventilation. <ul style="list-style-type: none"> o Check the both of the oven fans (see Figure 3-1). o Check both of the oven heaters. See Table 11-1 for OVEN TEMP WARNING .

(table continued)

Table 11-2: Test Functions - Indicated Failures

TEST FUNCTIONS (As Displayed)	INDICATED FAILURE(S)
PHT DRIVE	If this drive voltage is out of range it may indicate one of several problems: - A poor mechanical connection between the various components in inside the detector housing - An electronic failure of the IR Photo-Detector's built-in cooling circuitry, or; - A temperature problem inside the analyzer chassis. In this case other temperature warnings would also be active such as OVEN TEMP WARNING , BENCH TEMP WARNING or BOX TEMP WARNING .
SLOPE	Values outside range indicate Contamination of the zero air or span gas supply Instrument is Miscalibrated Blocked gas flow Contaminated or leaking GFC wheel (either chamber) Faulty IR photo-detector Faulty sample faulty IR photo-detector pressure sensor (P1) or circuitry Invalid M/R ratio (see above) Bad/incorrect span gas concentration due.
OFFSET	Values outside range indicate Contamination of the zero air supply Contaminated or leaking GFC wheel (either chamber) Faulty IR photo-detector

11.2.2. RELAY BOARD STATUS LED'S

The information found in Section 11.1.4.3 of the M300E/EM Operators Manual (P/N 04288) is applicable to the M300EU with the following exception:

- The following table replaces Table 11-5 of the M300E/EM Operators Manual.

Table 11-3: Relay Board Status LED Failure Indications

LED	FUNCTION	SIGNAL I/O PARAMETER		DIAGNOSTIC TECHNIQUE
		ACTIVATED BY	VIEW RESULT	
D2 Yellow	WHEEL HEATER	WHEEL_HEATER	WHEEL_TEMP	Voltage displayed should change. If not: Failed Heater Faulty Temperature Sensor Failed AC Relay Faulty Connectors/Wiring
D3 Yellow	BENCH HEATER	BENCH_HEATER	BENCH_TEMP	Voltage displayed should change. If not: Failed Heater Faulty Temperature Sensor Failed AC Relay Faulty Connectors/Wiring
D4 Yellow	OVEN HEATERS	OVEN_HEATER	OVEN_TEMP	Voltage displayed should change. If not: Failed Oven Heater(s) Failed Oven Fans(s) Faulty Oven Temperature Sensor Failed AC Relay Faulty Connectors/Wiring
D5 Green	SAMPLE/CAL GAS VALVE OPTION	CAL_VALVE	N/A	Sample/Cal Valve should audibly change states. If not: Failed Valve Failed Relay Drive IC on Relay Board Failed Relay Board Faulty +12 VDC Supply (PS2) Faulty Connectors/Wiring
D6 Green	ZERO/SPAN GAS VALVE OPTION	SPAN_VALVE	N/A	Zero/Span Valve should audibly change states. If not: Failed Valve Failed Relay Drive IC on Relay Board Failed Relay Board Faulty +12 VDC Supply (PS2) Faulty Connectors/Wiring
D7 Green	SHUTOFF VALVE OPTION	SHUTOFF_VALVE	N/A	Shutoff Valve should audibly change states. If not: Failed Valve Failed Relay Drive IC on Relay Board Failed Relay Board Faulty +12 VDC Supply (PS2) Faulty Connectors/Wiring
D8 Green	IR SOURCE	IR_SOURCE	CO_MEASURE	Voltage displayed should change. If not: Failed IR Source Faulty +12 VDC Supply (PS2) Failed Relay Board Failed IR Photo-Detector Failed Sync/Demod Board Faulty Connectors/Wiring

11.3. GAS FLOW PROBLEMS

Along with the information found in Section 11.2 of the M300E/EM Operators Manual (P/N 04288), also be aware that problems with the flow of gas through the Nafion[®] dryer could also be a cause of pressure or flow problems through the M300EU. Poor gas flow or leaks related to the dryer can also cause it to not dry the sample gas efficiently allowing extra H₂O to interfere with the analyzer's CO measurements.

In addition to the checks described in the M300E/EM Operators Manual

- Check for blockages in the dryer.
- Check for leakage in and around the dryer and its fixtures (both the wet gas stream and the purge gas inlets/outlets).

If it becomes necessary to replace the Nafion[®] dryer, contact Teledyne Instruments' Customer Service (see Section 11.6) for parts and instructions.

11.4. OTHER PERFORMANCE PROBLEMS

The information found in Section 11.4 of the M300E/EM Operators Manual (P/N 04288) is applicable to the M300EU with the following addition.

11.4.1. Unexplained DRIFT

Because the M300EU makes higher resolution CO measurements than the M300E/EM, subtle issues with certain subsystems that would be unimportant for the M300E/EM can affect its accuracy. The most common of these are:

- Temperature Coefficient issues related to the motherboard's A-to-D converter
- Age related changes to some of the optical bench components (e.g. the mirrors, the IR source, the IR detector, etc.)
- Ambient changes in the condition of the instrument or the sample gas.

If a drift problem exists and calibrating the instruments zero and span points does not correct the problem or there is no obvious component failure, perform the following operations in order:

1. Let the analyzer run uninterrupted for at least 2 hours
 - This will ensure that the entire oven area and all of the components therein have reached an equal and stable temperature.
2. Perform an Internal A-to-D Converter calibration (see Section 6.13.6.5 of the M300E/EM Operators Manual).
 - This should solve any issues related to the A/D converter.
3. Perform a Dark Calibration of the Optical Bench (see Section 6.13.7.2 of the M300E/EM Operators Manual).
 - This should account for any issues related to changes in the optical bench components.
4. Manually initiate an **A-REF** cycle (see Section 6.4.2).
 - This should account for any issues related to changes in the ambient conditions of the sample gas.

11.5. SUBSYSTEM CHECKOUT

11.5.1. RELAY BOARD

The information found in Section 11.5.5 of the M300E/EM Operators Manual (P/N 04288) is applicable to the M300EU with the following exception:

- The following table replaces Table 11-8 of the M300E/EM Operators Manual.

Table 11-4: Relay Board Control Devices

FUNCTION	CONTROL DEVICE	IN SOCKET
Wheel Heater	K1	Yes
Bench Heater	K2	Yes
OVEN HEATER	K3	YES
IZS Valves	U4	Yes
IR Source Drive	U5	No

11.5.2. MOTHERBOARD

11.5.2.1. A/D Functions

The M300EU makes higher resolution CO measurements than the M300E/EM means that it is susceptible to temperature coefficient issues related to the motherboard's A-to-D converter that could occur if the temperature of the motherboard differs significantly from that of the rest of the analyzer's oven area.

- Compare the values of the **BOX TEMP & OVEN TEMP** test functions. If they are significantly different check the function of the:
 - Oven heaters.
 - The oven heater fans.
 - The motherboard stabilization fan.
 - The relays controlling the oven heaters.
 - No abnormal blockages to airflow inside the oven area exist.

11.6. TECHNICAL ASSISTANCE

If this addendum and its trouble-shooting / repair sections do not solve your problems, technical assistance may be obtained from Teledyne Instruments, Customer Service, 9480 Carroll Park Drive, San Diego, CA 92121. Phone: +1 858 657 9800 or 1-800 324 5190. Fax: +1 858 657 9816. Email: api-customerservice@teledyne.com.

Before you contact customer service, fill out the problem report form in Appendix C, which is also available online for electronic submission at <http://www.teledyne-api.com/forms/index.asp>.

USER NOTES:

USER NOTES:

APPENDIX A - Version Specific Software Documentation

APPENDIX A-1: M300EU Software Menu Trees

APPENDIX A-2: M300EU Setup Variables Available Via Serial I/O

APPENDIX A-3: M300EU Warnings and Test Measurements Via Serial I/O

APPENDIX A-4: M300EU Signal I/O Definitions

APPENDIX A-5: M300EU iDAS Functions

APPENDIX A-1: M300EU Software Menu Trees, Revision K.6

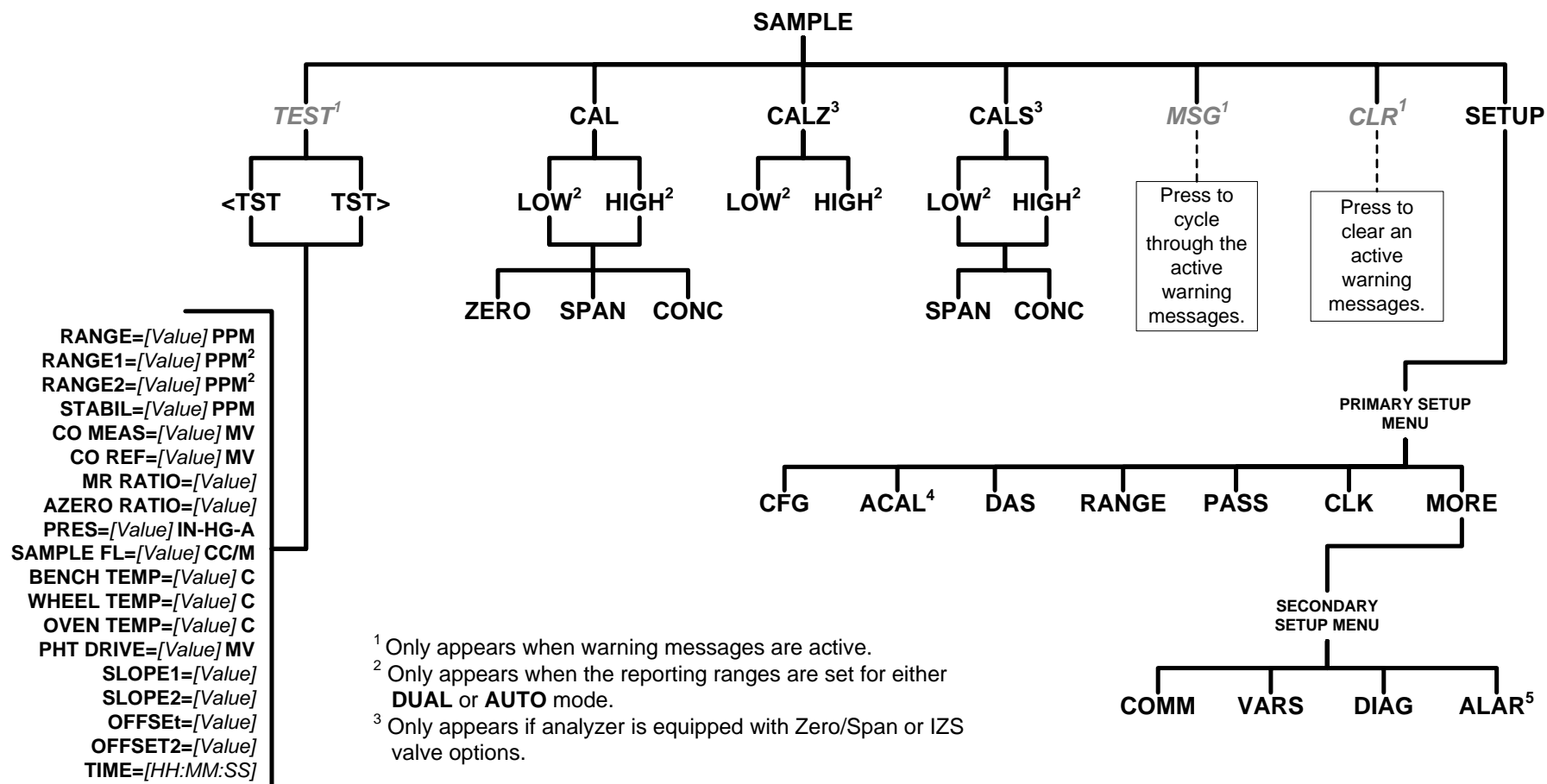

- ¹ Only appears when warning messages are active.
- ² Only appears when the reporting ranges are set for either **DUAL** or **AUTO** mode.
- ³ Only appears if analyzer is equipped with Zero/Span or IZS valve options.

Figure A-1: Basic Sample Display Menu

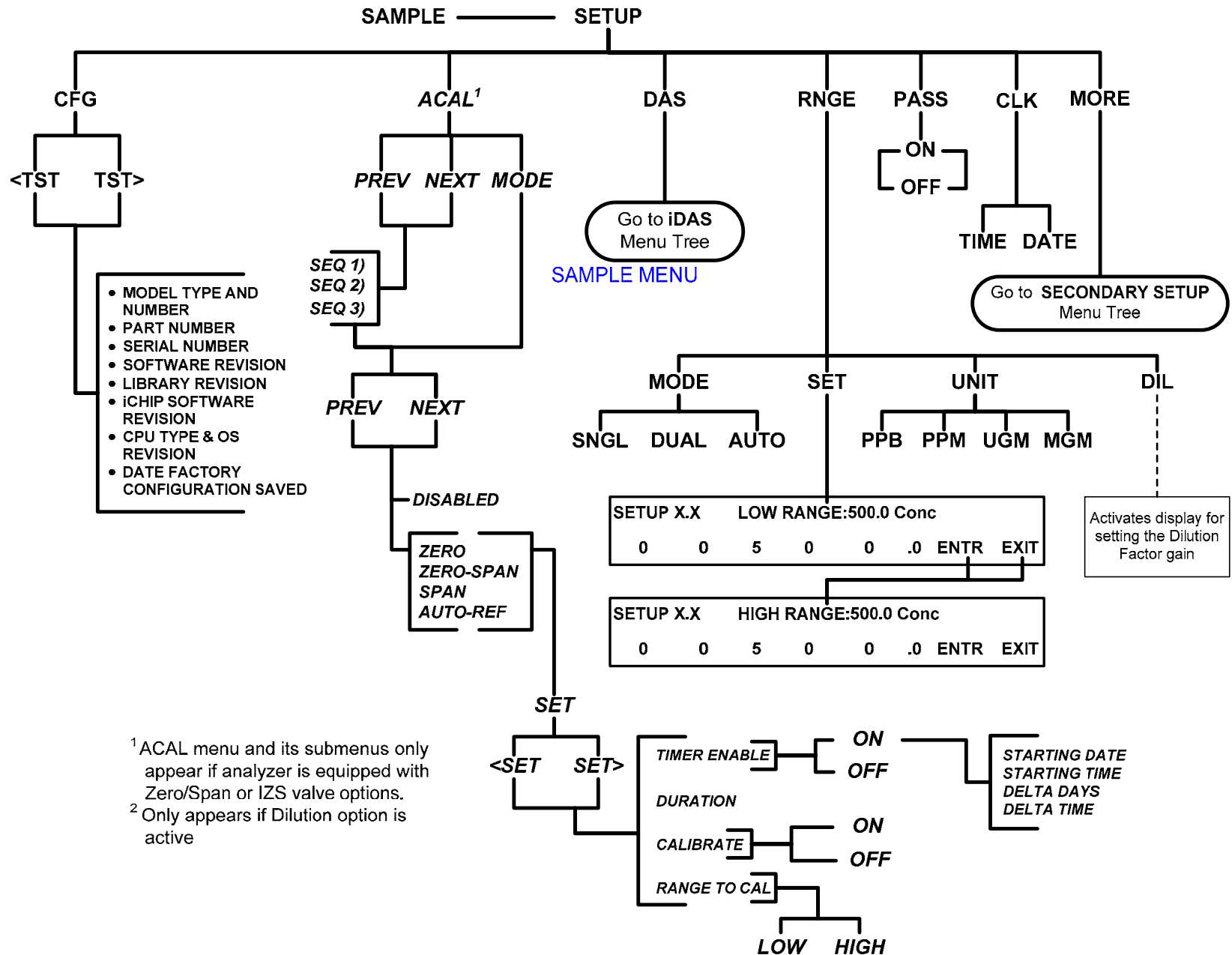
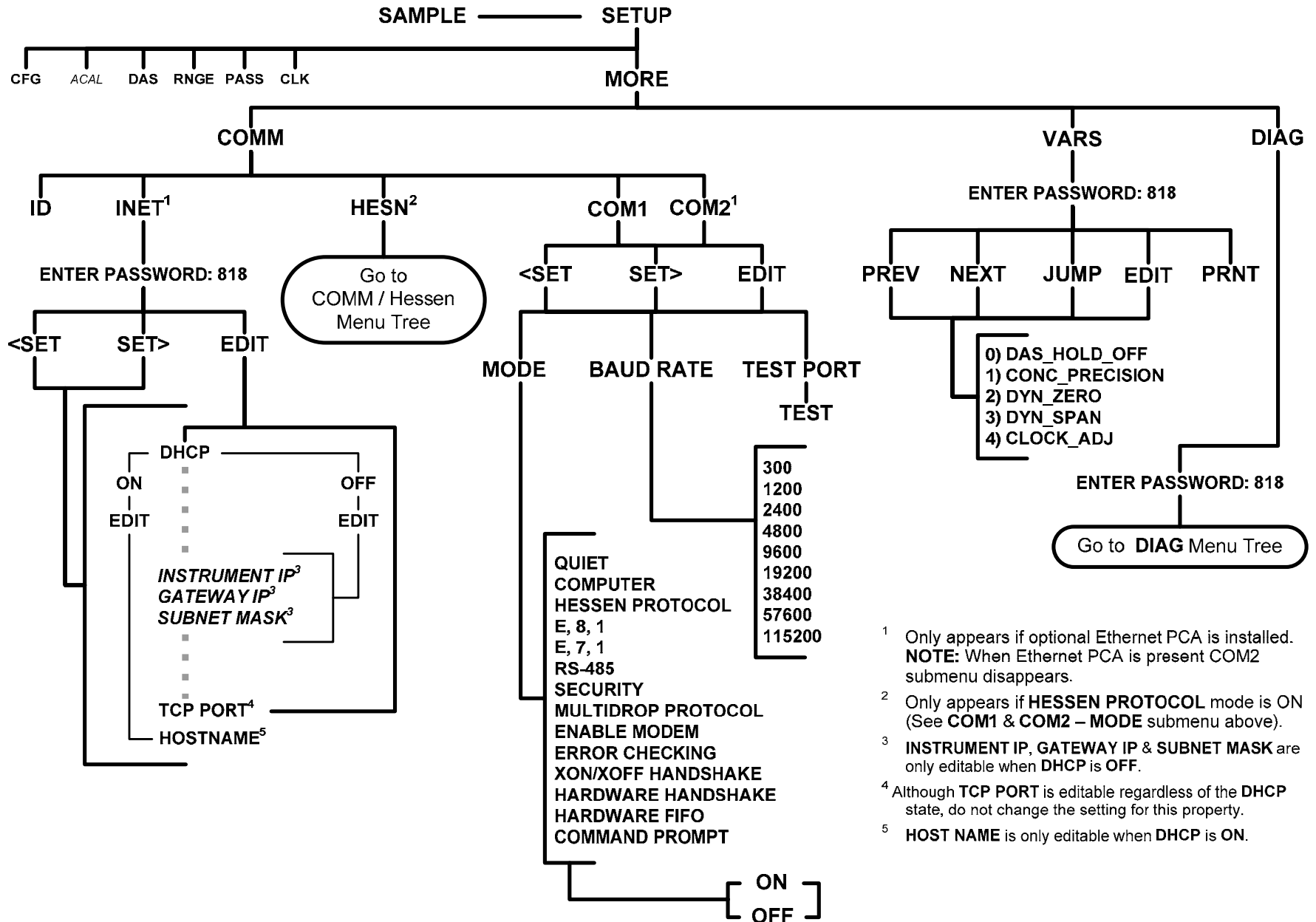
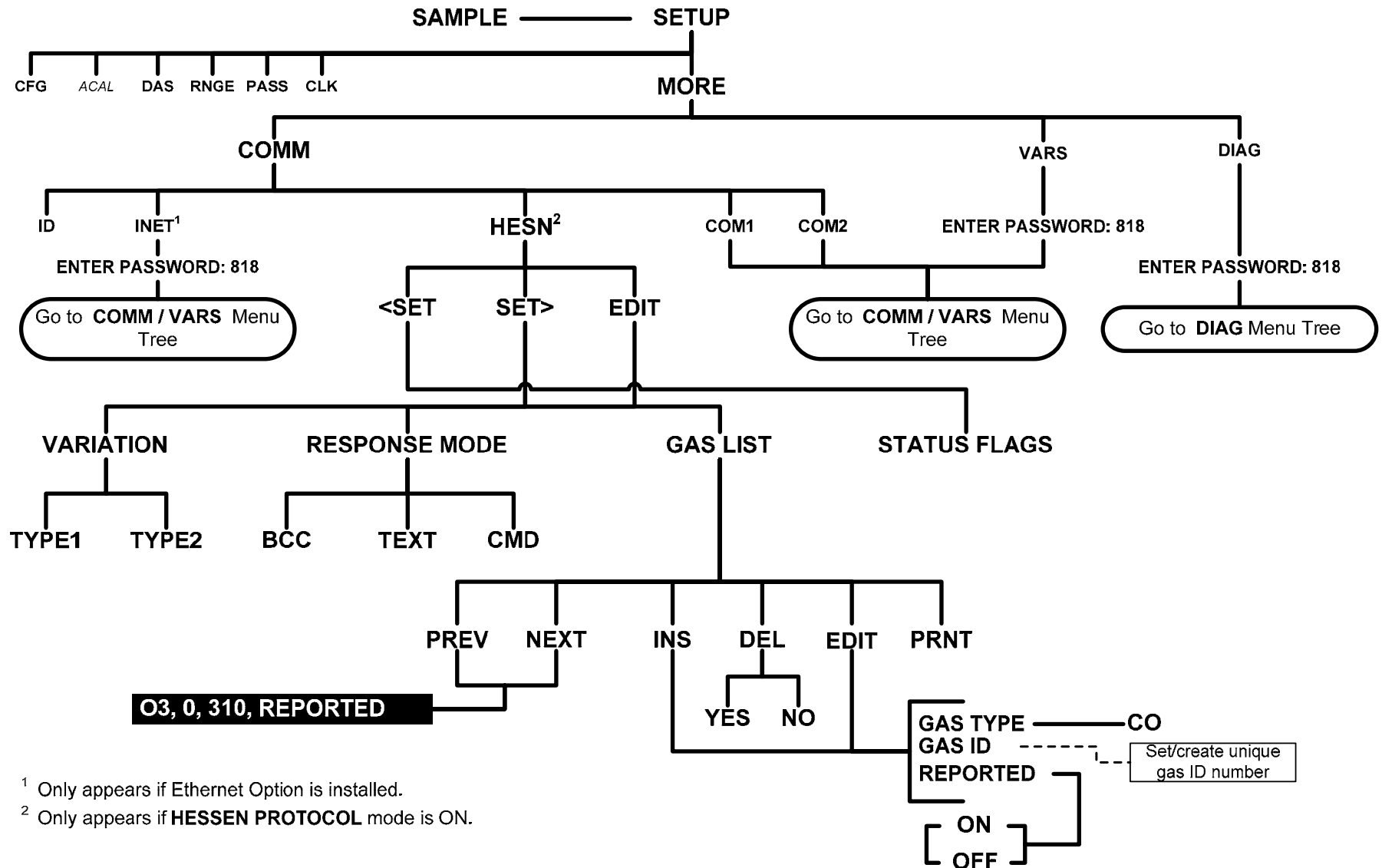

Figure A-2: Primary Setup Menu (Except iDAS)



- 1 Only appears if optional Ethernet PCA is installed. **NOTE:** When Ethernet PCA is present COM2 submenu disappears.
- 2 Only appears if **HESSEN PROTOCOL** mode is ON (See **COM1 & COM2 – MODE** submenu above).
- 3 **INSTRUMENT IP**, **GATEWAY IP** & **SUBNET MASK** are only editable when **DHCP** is OFF.
- 4 Although **TCP PORT** is editable regardless of the **DHCP** state, do not change the setting for this property.
- 5 **HOST NAME** is only editable when **DHCP** is ON.

Figure A-4: Secondary Setup Menu → COMM and VARS Submenus



¹ Only appears if Ethernet Option is installed.
² Only appears if HESSEN PROTOCOL mode is ON.

Figure A-5: Secondary Setup Menu → Hessen Protocol Submenu

APPENDIX A-2: Setup Variables For Serial I/O, Revision K.6

Table A-1: Additional or Changed Setup Variables Relevant to the M300EU, Revision K.6

SETUP VARIABLE	NUMERIC UNITS	DEFAULT VALUE	VALUE RANGE	DESCRIPTION
Low Access Level Setup Variables (818 password) Same as in the M300E/EM Operators Manual Appendix A (P/N 04906)				
STABIL_GAS	—	CO	CO, CO ₂ , O ₂	CO ₂ , O ₂ not applicable to the M300EU
Medium Access Level Setup Variables (929 password)				
CO_SAMPLE	Samples	4	1–30	Number of samples to take in measure or reference mode.
FILT_SIZE	Samples	1000	1–1000	Moving average filter size.
FILT_DELTA	PPM	0.7	1–1000	Absolute change to trigger adaptive filter.
CO_CONST1	—	78.8	100–50000	CO calculation constant.
CO_CONST2	—	1.458	0–10	CO calculation constant.
BENCH_SET	°C	48 Warnings: 34–53	0–100	Optical bench temperature set point and warning limits.
WHEEL_SET	°C	62 Warnings: 57–67	0–100	Wheel temperature set point and warning limits.
ZERO_APPLY_IN_CAL	—	ON	OFF, ON	ON applies auto-reference offset and dilution factor during zero/span calibration; OFF disables both
ZERO_DWELL	Minutes	3	1–60	Dwell time after closing or opening zero scrubber valve.
ZERO_SAMPLES	Samples	1000	1–1000	Number of zero samples to average.
ZERO_FILT_SIZE	Samples	5	1–100	Auto-zero offset moving average filter size.
ZERO_LIMIT	Ratio	1.15	0–5	Minimum auto-zero ratio allowed; must be <i>greater</i> than this value to be valid.
ZERO_CAL	Ratio	1.18	0.5–5	Calibrated auto-zero ratio.
CO_TARG_ZERO1	Conc.	0	-100.00–999.99	Target CO concentration during zero offset calibration of range 1.
CO_TARG_MID1	Conc.	50	0.01–9999.99	Target CO concentration during mid-point calibration of range 1.
CAL_BOX_TEMP1	°C	30	0–100	Calibrated box temperature for range 1.
CO_TARG_ZERO2	Conc.	0	-100.00–999.99	Target CO concentration during zero offset calibration of range 2.
CO_TARG_MID2	Conc.	50	0.01–9999.99	Target CO concentration during mid-point calibration of range 2.
CAL_BOX_TEMP2	°C	30	0–100	Calibrated box temperature for range 2.
TEST_CHAN_ID	—	NONE	Same as M300E/EM with following addition: TEMP4	Diagnostic analog output ID.
SAMP_FLOW_SET	cc/m	1800 Warnings: 1400–2500	0–5000	Sample flow warning limits. Set point is not used.
OVEN_SET	°C	46 Warnings: 41–51	0–100	Internal box temperature #2/oven set point and warning limits.
OVEN_CYCLE	Seconds	10	0.5–30	Internal box temperature #2/oven control cycle period.
Table continues				

SETUP VARIABLE	NUMERIC UNITS	DEFAULT VALUE	VALUE RANGE	DESCRIPTION
OVEN_PROP	1/°C	0.5	0–100	Internal box temperature #2/oven PID proportional coefficient. Proportional band is the reciprocal of this setting.
OVEN_INTEG	—	0.02	0–100	Internal box temperature #2/oven PID integral coefficient.
OVEN_DERIV	—	0	0–100	Internal box temperature #2/oven PID derivative coefficient.
OVEN_SET	°C	42 Warnings: 37–47	0–100	Internal box temperature #2/oven set point and warning limits.
BENCH_CYCLE	Seconds	15	0.5–30	Optical bench temperature control cycle period.
BENCH_PROP	1/°C	1.5	0–100	Optical bench temperature PID proportional coefficient. Proportional band is the reciprocal of this setting.
BENCH_INTEG	—	10.5	0–100	Optical bench temperature PID integral coefficient.
BENCH_DERIV	—	0	0–100	Optical bench temperature PID derivative coefficient.
WHEEL_CYCLE	Seconds	8	0.5–30	Wheel temperature control cycle period.
WHEEL_PROP	1/°C	0.3	0–100	Wheel temperature PID proportional coefficient. Proportional band is the reciprocal of this setting.
WHEEL_INTEG	—	0.06	0–100	Wheel temperature PID integral coefficient.
WHEEL_DERIV	—	0	0–100	Wheel temperature PID derivative coefficient.

Table A-2: M300E/EM Setup Variables Not Applicable to the M300EU, Revision K.6

Because the CO₂ and O₂ sensor options are not available on the M300EU, the following variables listed in Appendix A-2 of the M300E/EM Operators Manual (P/N 04288) are not present in the M300EU software.

SETUP VARIABLE	NUMERIC UNITS	DEFAULT VALUE	VALUE RANGE	DESCRIPTION
Medium Access Level Setup Variables (929 password)				
CO2_DWELL	Seconds	0.1	0.1–30	Dwell time before taking each sample.
CO2_FILT_ADAPT	—	ON	ON, OFF	ON enables CO ₂ adaptive filter; OFF disables it.
CO2_FILT_SIZE	Samples	48	1–300	CO ₂ moving average filter size.
CO2_FILT_ASIZE	Samples	12	1–300	CO ₂ moving average filter size in adaptive mode.
CO2_FILT_DELTA	%	2	0.01–10	Absolute CO ₂ conc. change to trigger adaptive filter.
CO2_FILT_PCT	%	10	0.1–100	Percent CO ₂ conc. change to trigger adaptive filter.
CO2_FILT_DELAY	Seconds	90	0–300	Delay before leaving CO ₂ adaptive filter mode.
CO2_DIL_FACTOR	—	1	0.1–1000	Dilution factor for CO ₂ . Used only if is dilution enabled with <i>FACTORY_OPT</i> variable.
O2_DWELL	Seconds	1	0.1–30	Dwell time before taking each sample.
O2_FILT_ADAPT	—	ON	ON, OFF	ON enables O ₂ adaptive filter; OFF disables it.
O2_FILT_SIZE	Samples	60	1–500	O ₂ moving average filter size in normal mode.
O2_FILT_ASIZE	Samples	10	1–500	O ₂ moving average filter size in adaptive mode.
O2_FILT_DELTA	%	2	0.1–100	Absolute change in O ₂ concentration to shorten filter.
<i>Table continues</i>				

SETUP VARIABLE	NUMERIC UNITS	DEFAULT VALUE	VALUE RANGE	DESCRIPTION
O2_FILT_PCT	%	2	0.1–100	Relative change in O ₂ concentration to shorten filter.
O2_FILT_DELAY	Seconds	20	0–300	Delay before leaving O ₂ adaptive filter mode.
O2_DIL_FACTOR	—	1	0.1–1000	Dilution factor for O ₂ . Used only if is dilution enabled with <i>FACTORY_OPT</i> variable.
CO2_COMP_ENABLE	—	OFF	ON, OFF	ON enables CO ₂ compensation; OFF disables it.
CO2_COMP_CONC	%	0	0–20	CO ₂ concentration to compensate for.
O2_CELL_SET	°C	50 Warnings: 45–55	30–70	O ₂ sensor cell temperature set point and warning limits.
STD_O2_CELL_TEMP	°K	323	1–500	Standard O ₂ cell temperature for temperature compensation.
ZERO_ENABLE	—	ON, OFF	OFF, ON	ON enables auto-zero calibration using scrubber; OFF disables it.
ZERO_FREQ	Minutes	5	0.1–1440	Auto-zero calibration period.
CO2_TARG_SPAN_CONC	%	12	0.1–1000	Target CO ₂ concentration during span calibration.
CO2_SLOPE	—	1	0.5–5	CO ₂ slope.
CO2_OFFSET	%	0	-10–10	CO ₂ offset.
O2_TARG_SPAN_CONC	%	20.95	0.1–100	Target O ₂ concentration during span calibration.
O2_SLOPE	—	1	0.5–2	O ₂ slope.
O2_OFFSET	%	0	-10–10	O ₂ offset.
CO2_RANGE	%	15	0.1–500	CO ₂ concentration range.
O2_RANGE	%	100	0.1–500	O ₂ concentration range.
O2_CELL_CYCLE	Seconds	10	0.5–30	O ₂ cell temperature control cycle period.
O2_CELL_PROP	—	1	0–10	O ₂ cell PID temperature control proportional coefficient.
O2_CELL_INTEG	—	0.1	0–10	O ₂ cell PID temperature control integral coefficient.
O2_CELL_DERIV	—	0 (disabled)	0–10	O ₂ cell PID temperature control derivative coefficient.

APPENDIX A-3: Warnings and Test Functions, Revision K.6

Table A-3: Additional or Changed Relevant to the M300EU Warning Messages, Revision K.6

NAME	MESSAGE TEXT	DESCRIPTION
WAUTOZERO	AZERO WARN 1.001	Auto-reference ratio below limit specified by <i>ZERO_LIMIT</i> variable.
WBOXTEMP2	BOX TEMP2 WARNING	Chassis temperature outside of warning limits specified by <i>BOX_SET2</i> variable.
WOVENTEMP	OVEN TEMP WARNING	Oven temperature outside of warning limits specified by <i>OVEN_SET</i> variable.

Table A-4: M300E/EM Warning Messages Not Applicable to the M300EU, Revision K.6

Because the CO₂ and O₂ sensor options are not available on the M300EU, the following warning messages listed in Appendix A-3 of the M300E/EM Operators Manual (P/N 04288) are not present in the M300EU software.

NAME	MESSAGE TEXT	DESCRIPTION
WCONCALARM1	CONC ALARM 1 WARN	Concentration limit 1 exceeded.
WCONCALARM2	CONC ALARM 2 WARN	Concentration limit 2 exceeded.
WO2CELLTEMP ²	O2 CELL TEMP WARN	O ₂ sensor cell temperature outside of warning limits specified by <i>O2_CELL_SET</i> variable.

Table A-5: Additional or Changed Test Function Relevant to the M300EU , Revision K.6

TEST FUNCTION NAME	MESSAGE TEXT	DESCRIPTION
STABILITY	STABIL=0.0 PPM	These gases not applicable to the M300EU
AUTOZERO	AZERO RATIO=1.234	Measure/reference ratio during auto-reference.
BOXTEMP2	BOX TEMP2=29.6 C	Internal box temperature #2.
OVENTEMP	OVEN TEMP=30.1 C	Oven temperature

Table A-6: M300E/EM Test Function Not Applicable to the M300EU, Revision K.6

Because the CO₂ and O₂ sensor options are not available on the M300EU, the following test functions listed in Appendix A-2 of the M300E/EM Operators Manual (P/N 04288) are not present in the M300EU software.

TEST FUNCTION NAME	MESSAGE TEXT	DESCRIPTION
CO2RANGE	CO2 RANGE=20 % ¹	CO ₂ range.
O2RANGE	O2 RANGE=100 % ²	O ₂ range.
[STABILITY]	CO STB=0.0 PPM ^{1,2} CO2 STB=0.0 % ¹ O2 STB=0.0 % ²	These gases not applicable to the M300EU
O2CELLTEMP	O2 CELL TEMP=50.2 C	O ₂ sensor cell temperature.
CO2SLOPE	CO2 SLOPE=1.000	CO ₂ slope, computed during zero/span calibration.
CO2OFFSET	CO2 OFFSET=0.000	CO ₂ offset, computed during zero/span calibration.
O2SLOPE	O2 SLOPE=0.980	O ₂ slope, computed during zero/span calibration.
O2OFFSET	O2 OFFSET=1.79 %	O ₂ offset, computed during zero/span calibration.

APPENDIX A-4: Signal I/O Definitions for 300E/EM Series Analyzers, Rev. K.6

Table A-7: Additional or Changed Test Signal I/O Definitions for M300EU, Revision K.6

Signal Name	Bit or Channel Number	Description
A status outputs, U24, J1017, pins 1–8 = bits 0–7, default I/O address 323 hex		
ST_AUTO_REF	6	0 = in auto-reference mode 1 = not in auto-reference mode
ST_CONC_ALARM_2	7	0 = conc. limit 2 exceeded 1 = conc. OK
A status outputs, U24, J1017, pins 1–8 = bits 0–7, default I/O address 323 hex		
ST_AUTO_REF	6	0 = in auto-reference mode 1 = not in auto-reference mode
Relay board digital output (PCF8574), default I ² C address 44 hex		
OVEN_HTR	3	0 = oven heaters on 1 = off

Table A-8: M300E/EM Signal I/O Definitions Not Applicable to the M300EU, Revision K.6

Because the CO₂ and O₂ sensor options are not available on the M300EU, the following signals listed in Appendix A-4 of the M300E/EM Operators Manual (P/N 04288) are not present in the M300EU software.

Signal Name	Bit or Channel Number	Description
Alarm outputs, U21, J1009, pins 1–12 = bits 4–7, default I/O address 325 hex		
ST_CONC_ALARM_1	5	1 = conc. limit 1 exceeded 0 = conc. OK
ST_CONC_ALARM_2	6	1 = conc. limit 2 exceeded 0 = conc. OK
A status outputs, U24, J1017, pins 1–8 = bits 0–7, default I/O address 323 hex		
ST_CONC_ALARM_1	6	0 = conc. limit 1 exceeded 1 = conc. OK
ST_CONC_ALARM_2	7	0 = conc. limit 2 exceeded 1 = conc. OK
Relay board digital output (PCF8574), default I ² C address 44 hex		
O2_CELL_HEATER ⁵	3	0 = O ₂ sensor cell heater on 1 = off
Rear board primary MUX analog inputs		
O2_SENSOR	10	O ₂ concentration sensor
CO2_SENSOR	12	CO ₂ concentration sensor
Rear board temperature MUX analog inputs		
TEMP_INPUT_5	5	Diagnostic temperature input

APPENDIX A-5: M300EU iDAS Parameters Revision K.6

Table A-9: Additional or Changed iDAS Trigger Events for M300EU, Revision K.6

NAME	DESCRIPTION
AZEROW	Auto-zero warning
OVTMPW	Internal box temperature #2/oven warning

Table A-10: M300E/EM iDAS Trigger Events Not Applicable to the M300EU, Revision K.6

Because the CO₂ and O₂ sensor options are not available on the M300EU, the following iDAS triggers listed in Appendix A-2 of the M300E/EM Operators Manual (P/N 04288) are not present in the M300EU software.

NAME	DESCRIPTION
EXITC2	Exit CO ₂ calibration mode
CO2SLC	CO ₂ slope and offset recalculated
O2SLPC	O ₂ slope and offset recalculated
O2TMPW	O ₂ sensor cell temperature warning

Table A-9: Additional or Changed iDAS Functions for M300EU, Revision K.6

NAME	DESCRIPTION	UNITS
AZERO	Auto-zero reading	M/R
OVNTMP	Internal box temperature #2/oven	°C
OVNDTY	Internal box temperature #2/oven control duty cycle	Fraction (0.0 = off, 1.0 = on full)

Table A-9: M300E/EM iDAS Functions Not Applicable to the M300EU, Revision K.6

Because the CO₂ and O₂ sensor options are not available on the M300EU, the following iDAS functions listed in Appendix A-2 of the M300E/EM Operators Manual (P/N 04288) are not present in the M300EU software.

NAME	DESCRIPTION	UNITS
CO2SLP ¹	CO ₂ slope	none
CO2OFS ¹	CO ₂ offset	%
O2SLPE ³	O ₂ slope	none
O2OFST ³	O ₂ offset	%
CO2ZSC ¹	CO ₂ concentration during zero/span calibration, just before computing new slope and offset	%
O2ZSCN ³	O ₂ concentration during zero/span calibration, just before computing new slope and offset	%
CO2CNC ¹	CO ₂ concentration	%
O2CONC ³	O ₂ concentration	%
O2TEMP ³	O ₂ sensor cell temperature	°C
BOXTMP	Internal box temperature	°C
TEST7	Diagnostic test input (TEST_INPUT_7)	mV
TEST8	Diagnostic test input (TEST_INPUT_8)	mV
TEMP5	Diagnostic temperature input (TEMP_INPUT_5)	°C

APPENDIX A-6: Terminal Command Designators, Revision K.6

The information found in Appendix A-6 of the M300E/EM Operators Manual (P/N 04906) is applicable to the M300EU .

USER NOTES:

APPENDIX B - M300EU SPARE PARTS & EXPENDABLES

NOTE

Use of replacement parts other than those supplied by API may result in non-compliance with European standard EN 61010-1.

- 04832 – Spare Parts List M300EU
- 05892 – Recommended Spare Parts Stocking Levels M300EU

USER NOTES